

REVISIONS				
ZONE	REV.	DESCRIPTION	DATE	APPROVED
	B	Ref. for catalog	4/16/2019	DEP
	C	Removed tolerance chart	9/4/2019	DEP

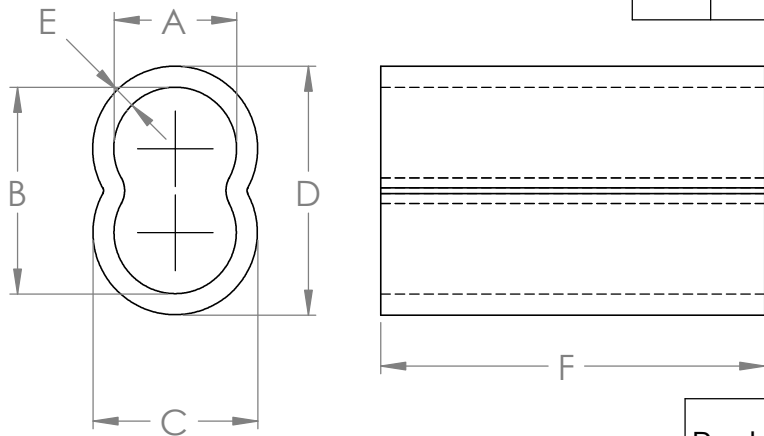

Part No.	Wire Size	A (Ref.)	B (Ref.)	C (Ref.)	D (Ref.)	E (Ref.)	F (Ref.)
SL1-3R	1/8	.163	.296	.250	.383	.043	.500
SL1-4R	5/32	.226	.382	.336	.492	.0545	.625
SL1-5R	3/16	.257	.444	.367	.554	.0545	.687
SL1-6R	1/4	.319	.538	.429	.648	.0545	1.000
SL1-7R	5/16	.382	.632	.492	.742	.0545	1.062
SL1-8R	3/8	.444	.725	.553	.834	.054	1.125
SL1-9R	3/8	.444	.757	.570	.883	.0625	1.188
SL1-10R	7/16	.538	.882	.679	1.023	.070	1.250
SL1-12R	1/2	.601	1.007	.758	1.164	.078	1.437

B

B

A

A

**PROPRIETARY AND CONFIDENTIAL**  
 THE INFORMATION CONTAINED IN THIS DRAWING IS THE SOLE PROPERTY OF LOOS & CO. INC. ANY REPRODUCTION IN PART OR AS A WHOLE WITHOUT THE WRITTEN PERMISSION OF LOOS & CO. INC. IS PROHIBITED.

MATERIAL  
**6063 Alum. Alloy**  
 FINISH  
**NONE**

	NAME	DATE
DRAWN	YD	4/16/19
CHECKED	BG	4/16/19
ENG APPR.	DEP	4/16/19

COMMENTS:  
 DO NOT SCALE DRAWING

TITLE: **LOOS & CO.**  
 CABLEWARE® DIVISION  
 Commercial Aluminum Oval Sleeves, Rope

SIZE	DWG. NO.	REV
<b>A</b>	<b>SL1-R CATALOG</b>	<b>C</b>

SCALE: 2:1