



901 INDUSTRIAL BLVD.
NAPLES, FL 34104

COMPLIES WITH
NFPA-13 2019*

loosseismicbracing.com
800.321.LOOS (5667)

LOOS & CO. INC.

CABLEWARE® DIVISION
• SEISMIC BRACING CABLE •

SEISMIC DESIGN GUIDE
CABLE BRACING SYSTEM



* Loos & Co. Seismic Cable Bracing Products is not affiliated with or endorsed by NFPA.

SECTION 1- GENERAL INFORMATION

1	Preface
1	General Introduction
2	Application
2	Reprint Permission Restrictions
2	Seismic Calculator
2	Video How-Tos
3-7	Hand Tool Information
9	Eye and Lap Splice Instructions
10	Description of Cable Kit Part Numbers

SECTION 2 - PRODUCTS

12-15	Bulk Cable Spools
16-17	Zinc-Plated Oval Sleeves
18-24	Seismic Anchoring Fitting (SAF) Series
25-29	Seismic Attachment Fitting Retrofit (SAFR) Series
30-36	Seismic Attachment Fitting 2 (SAF2) Series
37-41	Seismic Attachment Fitting Retrofit 2 (SAFR2) Series
42-49	Low-Pry Fitting (LPF) Series
50-58	Cable Kits

SECTION 3 - INSTALLATION INSTRUCTIONS

60	Lateral Bracing Installation
61	Longitudinal Bracing Installation
62	4-Way Bracing Installation
63	Splicing Info
64-72	Installation - Angles A, B, and C
73-80	Installation - Angles D, E, and F
81-88	Installation - Angles G, H, and I
89	Bar Joist Loop Installation
90	Riser Bracing - Angle Roof
91	Riser Bracing - Flat Roof
92	Riser Bracing- Wall Installation
93	Clevis Pin Installation
94	Pipe Hanger Installation

SECTION 4 - APPENDIX

96	Applied Load
97-102	Misc. Loads
103	CPVC Pipe Weights
104	Schedule 7 Pipe Weights
105	Schedule 10 Pipe Weights
106	Schedule 40 Pipe Weights
107	Concrete Anchor Orientations & Respective Prying Factor Formulas
108	Seismic Coefficient Table

PREFACE

Whether it's drawn stainless steel wire, aircraft cable, seismic cable assemblies, fittings, or tools, **Loos & Co., Inc.** has what you are looking for. Our technical expertise, developed over the last sixty years, has enabled us to provide essential materials to various industries, including aerospace, automotive, medical, and industrial markets. We take pride in our technical abilities, modern manufacturing equipment and rigid quality control standards to guarantee on-time delivery to the most critical specifications.

Loos & Co., Inc. has earned its reputation by continuously meeting and exceeding the increasingly stringent safety requirements of the aerospace industry. We have taken that level of safety, combined with 60+ years of knowledge and expertise and applied this methodology to our Seismic Bracing Cable system.

Loos & Co., Inc. has been providing seismic bracing cable and hardware since 1993. What we have seen over the years is an evolution from what was once confusion and misconception to an industry that has gone above and beyond to embrace nationally accepted codes and standards. **Loos & Co., Inc.** has taken this position to the next level by obtaining all of the certifications required to make our Seismic Bracing Cable the most cost-effective. Loos & Co., Inc. is certified and listed by 3rd party independent test labs.

Loos & Co., Inc. certifications include:

- Third party listed (UL, Intertek, and ICC-ES) for use in complying with NFPA 13 for fire sprinkler systems.
- Third party listed (ICC-ES) for use in complying with the International Building Code (IBC).
- Third party tested/listed to verify that cable assemblies, including fittings, maintain the nominal breaking strength per ASCE 19, as required by IBC, ASCE 7, and NFPA-13.
- Have swaged end fittings as required by the 2018 IBC per ASCE 19-16, which does not permit wedge or clip-type fittings.
- Certify the minimum breaking strength of the sway bracing assemblies.
- Comply with NFPA-13, ASCE 19, the IBC and ASCE 7.
- Listed by the FBC for system compatibility with Lubrizol CPVC pipe. Visit fbcssystemcompatible.com for additional information. FBC™ is a trademark of Lubrizol Corporation. Made with Temp Rite® Technology.
- Listed as approved products in Spears CPVC Compatibility List

In this guide, you will find all of the specifications, descriptions and applicable drawings for all of the Seismic products **Loos & Co., Inc.** offers. This will allow the user to identify and specify the proper components to satisfy the code requirements of the local authority having jurisdiction (AHJ).

Thank you for your interest in our Seismic Cable Bracing System manufactured by **Loos & Co., Inc.**

GENERAL INTRODUCTION

Loos & Co.'s Seismic Design Guide will assist you in the design and installation of our Seismic Cable Bracing System. All of the materials and products presented have been designed and tested to exceed the requirements set forth in NFPA-13. In fact, the provisions of NFPA-13 directly provide for the use of tension only bracing where listed for this service and where installed in accordance with their listing limitations, including installation instructions. Ref. 9.3.5.4.2* in NFPA-13 Standard for the Installation of Sprinkler Systems **Loos & Co., Inc.** has been providing Seismic Cable Bracing since 1993 in structures located all over the world, both for new and retro-fit buildings.

APPLICATION OF THIS PUBLICATION

In this publication you will find information regarding proper installation techniques and guidelines applicable to **Loos & Co., Inc.** Seismic Cable Bracing System for meeting existing codes and standards. It has been compiled using proven engineering ethics and principles. Final accountability for approving specific designs, code interpretations, and/or installations rests with the engineer responsible for the specific design and/or the agency or authority having jurisdiction (AHJ). **Loos & Co., Inc.** and/or contributors to this publication assume no liability for the specific installation of its products or the design, application, approval, or interpretation of the requirements or guidelines contained in this publication. Users of this publication are encouraged to confer with certified design Engineers (P.E.) as well as all applicable Federal, State, and local regulations or requirements for specific installations.

REPRINT PERMISSION RESTRICTIONS

Permission is granted to government and private sector users of this publication to reproduce unaltered conceptual drawings from this publication for their use relating to the specific design, specification, installation, or approval of **Loos & Co., Inc.'s** Seismic Cable Bracing. Reproduction for the purpose of its sale is prohibited. Any other use or reproduction of this publication shall be first approved in writing by **Loos & Co., Inc.** Liability for the specific application of such information, including errors or omissions in reproduction is solely the responsibility of the party reproducing such material.

ENGINEERS' TOOLS - SEISMIC CALCULATOR

This Design Guide can be used in conjunction with our Engineers' Tools Seismic Design Calculator which is accessible for free from our website (www.loosseismicbracing.com). The Seismic Design Calculator allows the user to enter all the details for fire sprinkler installations from the building blueprints then print out the completed NFPA-13 form with all of the calculations complete and ready to submit to your local AHJ. As an added bonus, our Seismic Design Calculator software will also generate a Bill of Material based on input from the user. This Bill of Materials can then be utilized for quoting purposes.

VIDEO HOW-TOS

Visit our website (www.loosseismicbracing.com) for how-to installation videos in both English and Spanish. Look for the QR codes on many of Loos Seismic Bracing products for easy access.

Loos & Co., Inc. Cableware Division - Seismic Cable Bracing

901 Industrial Boulevard
Naples, Florida 34104
(800) 321-LOOS (5667)
www.loosseismicbracing.com

#0-3-SBHS HAND SWAGER

The preferred tool for swaging gold cable sleeves (#GO3-SLV) and orange cable sleeves (#OR4-SLV thin wall).



A well-made, economical handswaging tool for #GO3 cable sleeves and #OR4 thin wall cable sleeve, our most popular cable size. Loos offers the correct tools to use in swaging zinc-plated oval sleeves. Using the correct tool and following proper swaging instructions will ensure proper cable connections that actually exceed the breaking strength of the cable.

OPERATION INSTRUCTIONS

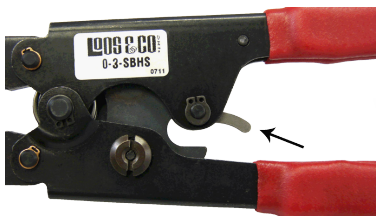

Figure 1



Figure 2

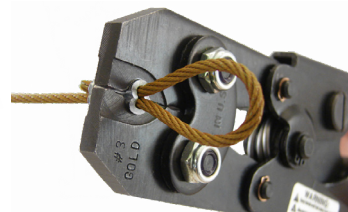

Figure 3



Figure 4

Cable Size	Number of Compressions
#GO3 (Gold)	2
#OR4 (Orange)*	4

*Thin wall sleeve

1. To open tool squeeze handles hard or push release lever (Figure 1) forward while squeezing handles to relieve tension.
2. Place the sleeve on the cable and make a loop around the item to which you are securing the cable.
3. Next, insert cable end through the sleeve and at least 1/8" or more beyond (Figure 2).
4. While holding sleeve in place, swage one compression. Move over and swage (second compression). Two compressions are required for Gold cable sleeve and four compressions for Orange cable thin wall sleeve. The tool won't release until compression is complete.
5. Check sleeve for proper after swage diameter with gauge provided (Figure 4). The clamping action of the ratchet allows the sleeve to be held by the tool before completing the swage. This allows for the user to adjust the position of the sleeve on the cable.
6. After swaging, excess cable may be cut off with Felco® C7 cutters (see page 8).

0-3/16SC HAND SWAGER

The preferred tool for swaging green cable (GR6-CBL).



A well-made, economical handswaging tool for swaging #GR6 (GREEN) cable sleeves. Loos offers the correct tools to use in swaging our zinc-plated oval sleeves.

Using the correct tool and following proper swaging instructions will ensure proper cable connections that actually exceed the breaking strength of the cable.

OPERATION INSTRUCTIONS

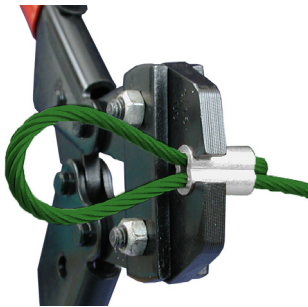

Cable Size	Number of Compressions
#GR6 (GREEN)	3

1. Place sleeve to be compressed in groove in swaging tool.
2. A length of cable (minimum) equal to the cable diameter should extend beyond the length of sleeve to achieve maximum holding.
3. Keep jaws of swaging tool at right angles to the sleeve to be compressed, making sure the sleeve is aligned in the jaw grooves.
4. Close tool completely. Tool handles should snap shut indicating complete closure.
5. Swage for proper number of compressions.
6. Use the swaging gauge provided with tool to check proper after swage diameter of sleeve. Compressed sleeve should slide freely into corresponding size in gauge.

#0-1/4 HAND SWAGER

The preferred tool for swaging black cable (#BL8-CBL).



A well-made, economical handswaging tool for swaging #BL8 (BLACK) cable sleeves. Loos offers the correct tools to use in swaging our zinc-plated oval sleeves.

Using the correct tool and following proper swaging instructions will ensure proper cable connections that actually exceed the breaking strength of the cable.

OPERATION INSTRUCTIONS



Cable Size	Number of Compressions
#BL8 (Black)	3

1. Place sleeve to be compressed in groove in swaging tool.
2. A length of cable (minimum) equal to the cable diameter should extend beyond the length of sleeve to achieve maximum holding.
3. Keep jaws of swaging tool at right angles to the sleeve to be compressed, making sure the sleeve is aligned in the jaw grooves.
4. Close tool completely. Tool handles should snap shut indicating complete closure.
5. Swage for proper number of compressions.
6. Use the swaging gauge provided with tool to check proper after swage diameter of sleeve. Compressed sleeve should slide freely into corresponding size in gauge.

#3-346SB HAND SWAGER

For #GO3, #OR4, and #GR6 cable



Each **Loos & Co., Inc.** #3-346SB swaging tool is designed to work with #GO3, #OR4 thin wall, and #GR6 zinc-plated copper oval sleeves. For use only on **Loos & Co., Inc.** Seismic Cable Bracing sizes #GO3, #OR4, and #GR6. Using the correct tool and following proper swaging instructions will ensure proper cable connections that actually exceed the breaking strength of the cable. You will not obtain proper performance or meet UL standards if you do not use the proper **Loos & Co., Inc.** swaging tool and sleeve combination.

OPERATION INSTRUCTIONS



Figure 1

Cable Size	Number of Compressions
#GO3 (Gold)	2
#OR4 (Orange)*	3
#GR6 (Green)	3

*Thin wall sleeve

Figure 2



1. Place sleeve to be compressed in proper groove in swaging tool by matching cable color to colored dot next to groove in tool (Figure 1).
2. A minimum length of cable equal to the cable diameter should extend beyond the length of sleeve to achieve maximum holding.
3. Keep jaws of swaging tool at right angles to the sleeve to be compressed, making sure the sleeve is aligned in the jaw grooves.
4. Close tool completely. Tool handles should snap shut indicating complete closure.
5. Swage for proper number of compressions (Figure 2).
6. Use the swaging gauge provided with the tool to check proper after-swage diameter of sleeve. Compressed sleeve should slide freely into corresponding color slot in gauge (Figure 3).

SL-7NDK-SB BATTERY-POWERED SWAGER

For #GO3, #OR4, #GR6 and #BL8 cable



A very well-made and powerful, state-of-the-art, battery-powered swaging tool that has replaceable swaging dies. This allows the user to have one reliable tool that will swage all sizes of Loos' zinc-plated oval sleeves.

OPERATION INSTRUCTIONS

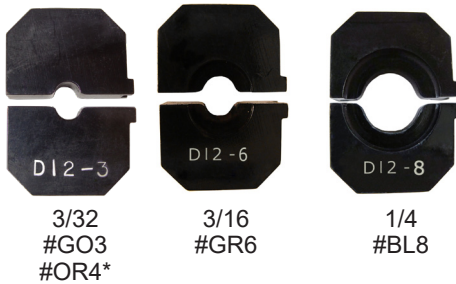

IMPORTANT: Alignment tabs (ears) must be fully seated towards open end of jaws. Die needs to fit all the way in. Otherwise it will break the alignment tab (ear) on corners or damage tool.

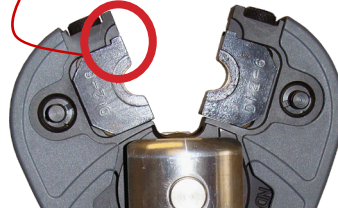

Cable Size	Number of Compressions
#GO3 (Gold)	1
#OR4 (Orange)*	1
#GR6 (Green)	2
#BL8 (Black)	3

*Thin wall sleeve

1. Insert correctly proper die set into opened jaw.
2. Place sleeve to be compressed into proper size die groove in swaging tool.
3. Press on the forward trigger to crimp the sleeve onto cable. An audible click advises when the swage is completed.
4. Open the jaws of the tool by pressing the retract trigger. You may now start another crimp cycle of the tool. Refer to the number of compressions table (figure). For lap splices, two sleeves should be used.



BATTERY CARTRIDGE



BATTERY CHARGER



CARRYING CASE

Loos & Co., Inc. offers the complete line of Swiss-made Felco® brand cable cutters. Felco® cutters are recognized around the world for their precision and cutting capabilities. They are lightweight enough for overhead cutting, and the plastic-coated handles afford a firm, comfortable grip. A cable when crushed or deformed in cutting is difficult to use with fittings. These cutters, with unique triangular cutting jaws, never leave a frayed end.

FELCO C7 CABLE CUTTER

Capacity: 5/32" diameter. For use with #GO3 (gold) and #OR4 (orange) cable
Length: 7.5" (190 mm)
Weight: 9.5 oz. (270 g)



FELCO C9 CABLE CUTTER

Replacement parts available from stock.



Capacity: 1/4" diameter. For use with #GO3 (gold), #OR4 (orange), GR6 (green) and #BL8 (black) cable
Length: 13" (325 mm)
Weight: 1.5 lbs. (750 g)

High-Strength Blades

Hardened and tempered blades for cutting the strongest of cables.

Triangular Cutting Action

Felco®'s innovative triangular cut allows you to progressively cut cable wires at the same time, to avoid squishing the strands. Thanks to this feature, it is generally not necessary to tie the cable before the cut.

Forged Aluminum Handles

Lightweight, strong, and sturdy thanks to special aluminum alloys and advanced precision forging methods.

INSTRUCTIONS FOR LAP SPLICING OF STEEL CABLE WITH LOCOLOC® SWAGERS

Cable splicing is much easier if the cable is cut clean without frayed ends. We highly recommend FELCO C7 or C9 cable cutters as shown on our website (www.loosseismicbracing.com).

Sleeves elongate after compression. To assure maximum holding allow the end of the cable to extend one cable diameter length beyond the sleeve after it is compressed (see illustration at right). The chart below indicates the recommended number of compressions for each size of sleeve to obtain maximum holding. Keep the jaws of the swager at right angles to the sleeve being compressed, making sure the sleeve is aligned in the jaw grooves. Then close the handles of the swager completely.

Lap splices can be used to extend a seismic cable that falls short of reaching a desired length or mounting point. Note: for lap splices, at least two oval sleeves should be used. See figure to the right.

Each Loos & Co. LOCOLOC® Swager is designed to work with one or more spec size sleeves. **FOR USE ON ALL METAL CONSTRUCTION CABLES, 7x7 & 7x19.** You will not obtain performance if you do not use the proper swager and sleeve combination. All compressions must be gauged to assure maximum holding strength.

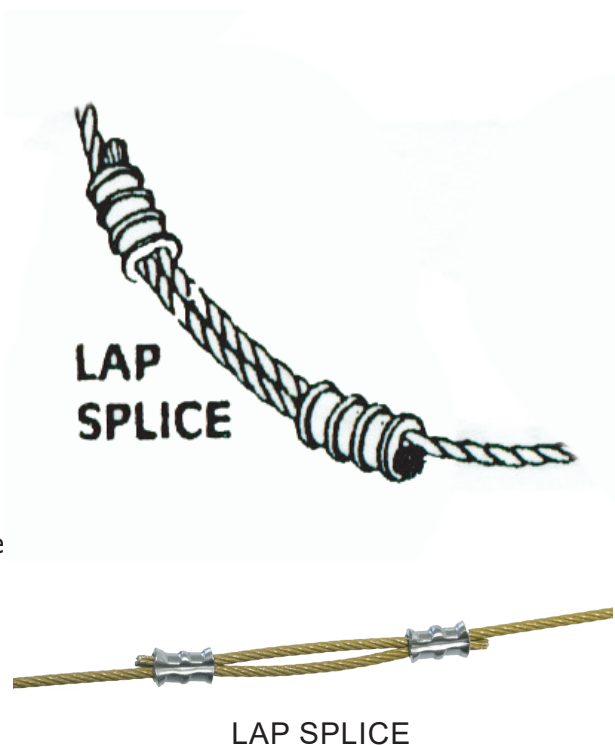

Tools and Sleeves			
Cable Color	Sleeve Size	Tool	Crimps
Gold	3/32"	#0-3-SBHS	2
		#3-346-SB	2
		SL-7NDK-SB3	1
Orange	1/8" *	#0-3-SBHS	4
		#3-346-SB*	3
		SL-7NDK-SB3	1
Green	3/16"	0-3/16SC	3
		#3-346-SB	3
		SL-7NDK-SB6	2
Black	1/4"	0-1/4	3
		SL-7NDK-SB8	3

* Thin wall sleeve using 3/32" cavity



DESCRIPTION OF STANDARD CABLE KIT PART NUMBERS

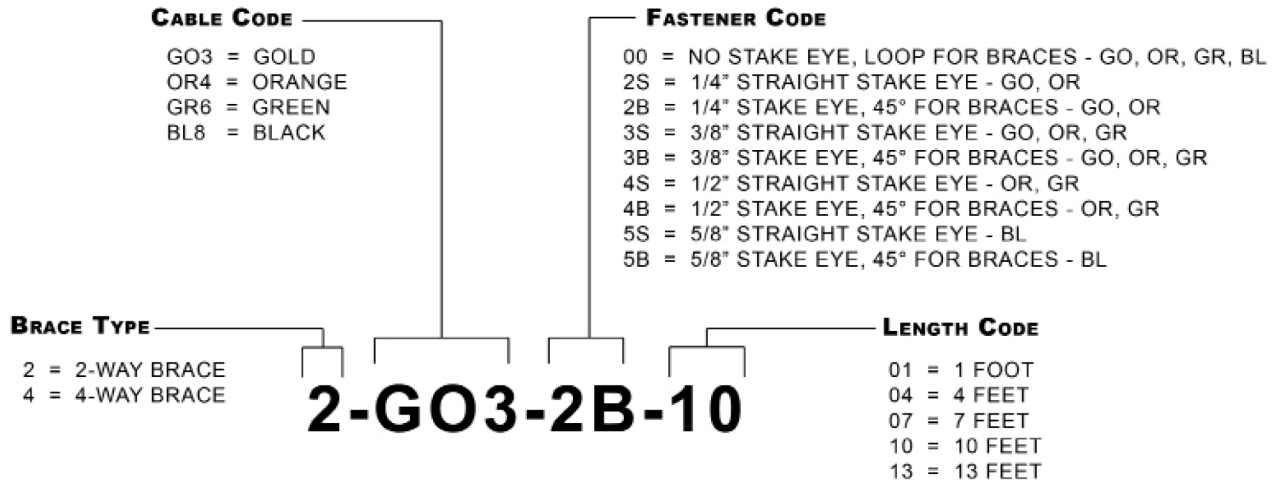

DETAILED CABLE KIT PART NUMBERS

1. Choose your brace type:

Brace Type	Description	To Fit Cable	Fastener Code
2	Two-Way	All	All
4	Four-Way	All	00, 2B, 3B, 4B, 5B

2: Choose the cable that best fits your load requirement:

Cable Code	Description	Fastener Code
GO3	Gold, 418 lb. Load Rating	00, 2S, 2B, 3S, 3B
OR4	Orange, 770 lb. Load Rating	00, 2S, 2B, 3S, 3B, 4S, 4B
GR6	Green, 1360 lb. Load Rating	00, 3S, 3B, 4S, 4B
BL8	Black, 3180 lb. Load Rating	00, 5S, 5B

3. Choose the fastener that best fits your requirement:

Fastener Code	Description	To Fit Cable
00	No Stake Eye, Loop	GO, OR, GR, BL
2S	1/4" Straight Stake Eye	GO, OR
2B	1/4" 45° Stake Eye	GO, OR
3S	3/8" Straight Stake Eye	GO, OR, GR
3B	3/8" 45° Stake Eye	GO, OR, GR
4S	1/2" Straight Stake Eye	OR, GR
4B	1/2" 45° Stake Eye	OR, GR
5S	5/8" Straight Stake Eye	BL
5B	5/8" 45° Stake Eye	BL

4. Choose desired brace length:

Length Code	Description	To Fit Cable
01	1 foot / 0.3 meters (+4 ft. / 1.2 meters extra)	All
04	4 feet / 1.2 meters (+4 ft. / 1.2 meters extra)	All
07	7 feet / 2.1 meters (+4 ft. / 1.2 meters extra)	All
10	10 feet / 3.0 meters (+4 ft. / 1.2 meters extra)	All
13	13 feet / 3.9 meters (+4 ft. / 1.2 meters extra)	All

PRODUCTS

Seismic Bracing Cable **Size #G03 (Gold)**



Certified Minimum Break Strength (lbs)	Allowable Load at 90° (lbs)	Allowable Load at 30° - 44° (lbs)	Allowable Load at 45° - 59° (lbs)	Allowable Load at 60° - 89° (lbs)	Min. Cable Diameter (in.)	Max. Cable Diameter (in.)
920	418	209	295	361	0.09375	0.10575

Wire Construction	Number of Wires	Nom. Dia. of Wires (in.)	Min. Stress at 0.7% Extension Under Load	Min. Ultimate Tensile Strength
7 x 7	49	.010 to .013	150,000 PSI	300,000 PSI

Applied Load (lbs)	Applied Load (% of Min. Break Strength)	% Elongation at Applied Load	Modulus of Elasticity
92	10%	0.15%	12.7 x 10 ⁶
184	20%	0.28%	14.6 x 10 ⁶
276	30%	0.40%	15.8 x 10 ⁶
368	40%	0.48%	17.7 x 10 ⁶
418	45.43%	0.54%	17.5 x 10 ⁶

*45.43% is equal to the allowable load (break strength ÷ 2.2)

Seismic Bracing Cable Size #OR4 (Orange)



Certified Minimum Break Strength (lbs)	Allowable Load at 90° (lbs)	Allowable Load at 30° - 44° (lbs)	Allowable Load at 45° - 59° (lbs)	Allowable Load at 60° - 89° (lbs)	Min. Cable Diameter (in.)	Max. Cable Diameter (in.)
1,700	770	385	544	666	.125	.139

Wire Construction	Number of Wires	Nom. Dia. of Wires (in.)	Min. Stress at 0.7% Extension Under Load	Min. Ultimate Tensile Strength
7 x 7	49	.014 to .015	150,000 PSI	300,000 PSI

Applied Load (lbs)	Applied Load (% of Min. Break Strength)	% Elongation at Applied Load	Modulus of Elasticity
170	10%	0.17%	11.0 x 10 ⁶
340	20%	0.30%	13.4 x 10 ⁶
510	30%	0.42%	14.7 x 10 ⁶
680	40%	0.52%	16.8 x 10 ⁶
773	45.43%	0.57%	17.1 x 10 ⁶

*45.43% is equal to the allowable load (break strength ÷ 2.2)

Seismic Bracing Cable Size #GR6 (Green)



Certified Minimum Break Strength (lbs)	Allowable Load at 90° (lbs)	Allowable Load at 30° - 44° (lbs)	Allowable Load at 45° - 59° (lbs)	Allowable Load at 60° - 89° (lbs)	Min. Cable Diameter (in.)	Max. Cable Diameter (in.)
4,200	1,900	950	1,343	1,645	.1875	.2055

Wire Construction	Number of Wires	Nom. Dia. of Wires (in.)	Min. Stress at 0.7% Extension Under Load	Min. Ultimate Tensile Strength
7 x 19	133	.0125 to .016	150,000 PSI	300,000 PSI

Applied Load (lbs)	Applied Load (% of Min. Break Strength)	% Elongation at Applied Load	Modulus of Elasticity
420	10%	0.17%	12.8 x 10 ⁶
840	20%	0.31%	14.6 x 10 ⁶
1,260	30%	0.44%	15.8 x 10 ⁶
1,680	40%	0.56%	17.1 x 10 ⁶
1,909	45.43%	0.58%	17.4 x 10 ⁶

*45.43% is equal to the allowable load (break strength ÷ 2.2)

Seismic Bracing Cable **Size #BL8 (Black)**



Certified Minimum Break Strength (lbs)	Allowable Load at 90° (lbs)	Allowable Load at 30° - 44° (lbs)	Allowable Load at 45° - 59° (lbs)	Allowable Load at 60° - 89° (lbs)	Min. Cable Diameter (in.)	Max. Cable Diameter (in.)
7,000	3,180	1,590	2,248	2,753	.250	.268

Wire Construction	Number of Wires	Nom. Dia. of Wires (in.)	Min. Stress at 0.7% Extension Under Load	Min. Ultimate Tensile Strength
7 x 19	133	.016 to .020	145,000 PSI	290,000 PSI

Applied Load (lbs)	Applied Load (% of Min. Break Strength)	% Elongation at Applied Load	Modulus of Elasticity
700	10%	0.20%	12.6 x 10 ⁶
1,400	20%	0.34%	14.6 x 10 ⁶
2,100	30%	0.47%	15.9 x 10 ⁶
2,800	40%	0.60%	16.3 x 10 ⁶
3,182	45.43%	0.66%	17.2 x 10 ⁶

*45.43% is equal to the allowable load (break strength ÷ 2.2)

#OR4 Thin Wall Zinc-Plated Oval Sleeves



Size	Cable Color	Certified Minimum Break Strength (lbs)	Load Rating (lbs)
#OR4	Orange	1,700	770

#OR4 thin wall zinc-plated oval sleeve are supplied by Loos & Co., Inc only. #OR4-SLV are certified to maintain the break strength of #OR4 cable. This sleeve was engineered to be able swage using the one-handed tool #0-3-SBHS.

Zinc-Plated Oval Sleeves



Size	Cable Color	Certified Minimum Break Strength (lbs)	Load Rating (lbs)
#GO3	Gold	920	418
#GR6	Green	4,200	1,900
#BL8	Black	7,000	3,180

All zinc-plated oval sleeves supplied by Loos & Co., Inc. are in full compliance with the requirements of Military-Specification MS51844, and are certified to maintain the break strength of the cable to which they are applied (for 3x7, 7x7, 7x19, and 6x19 construction).

SAF Series

Seismic Anchoring Fitting

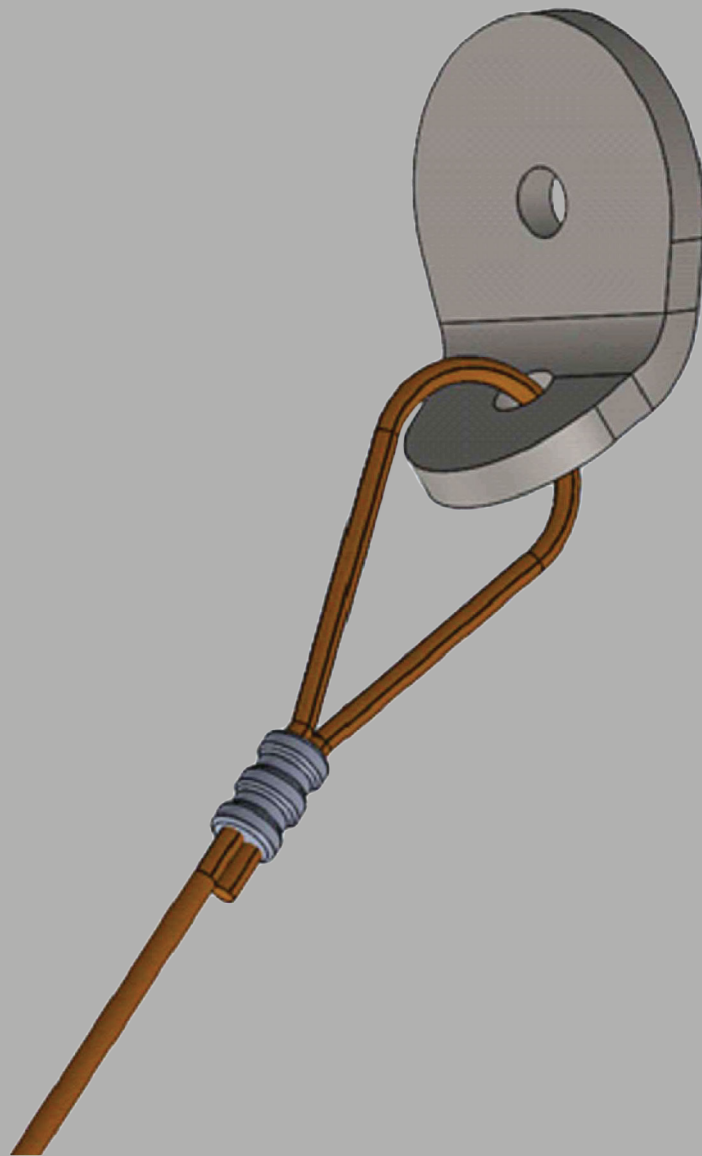

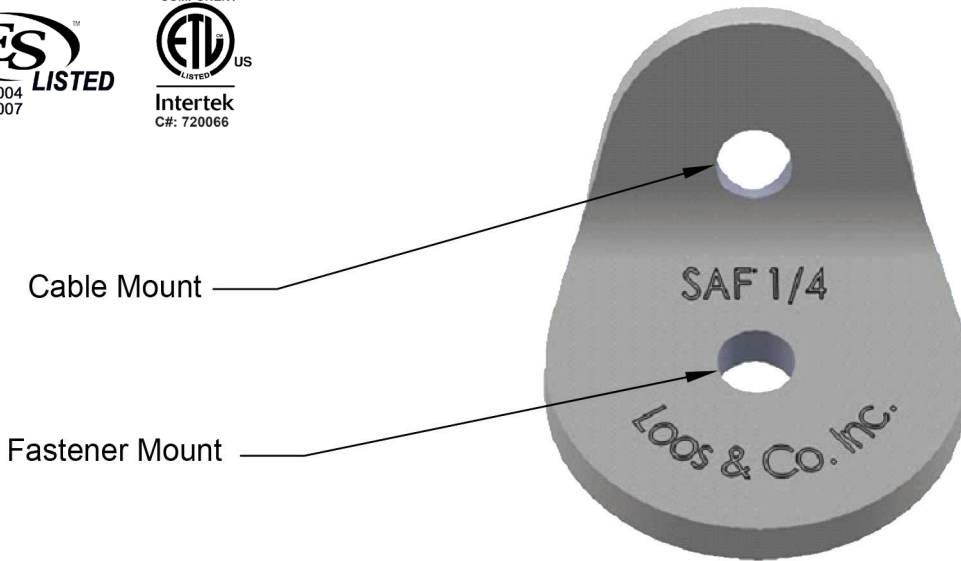

The SAF-1/4 is designed for use in attaching seismic cable bracing to steel structural members. The limitations of use are governed by the fastener diameter as a 1/4 inch (6mm) fastener is only listed for use with steel, as per NFPA-13. Will accept both metric and imperial fasteners. The cable mount will accept Gold, Orange, or Green cable.

Prying Factor			Prying Factor			Prying Factor		
Orientation 1			Orientation 2			Orientation 3		
Angle A	Angle B	Angle C	Angle D	Angle E	Angle F	Angle G	Angle H	Angle I
3.259	1.659	0.879	1.445	1.777	1.954	0.977	0.691	0.564

The SAF maintains the rated break strength of size #GO3 (gold), #OR4 (orange), and #GR6 (green) cable without the need for a thimble. The SAF may be used at both ends of the cable for anchoring equipment. SAFs are offered in 6 mounting sizes (SAF-1/4, SAF-3/8, SAF-1/2, SAF-5/8, SAF-3/4, and SAF-7/8).

UL Rated Load (lbs-f)	ICC-ES Breaking Strength (lbf)
1,900	1,700

SAF-3/8

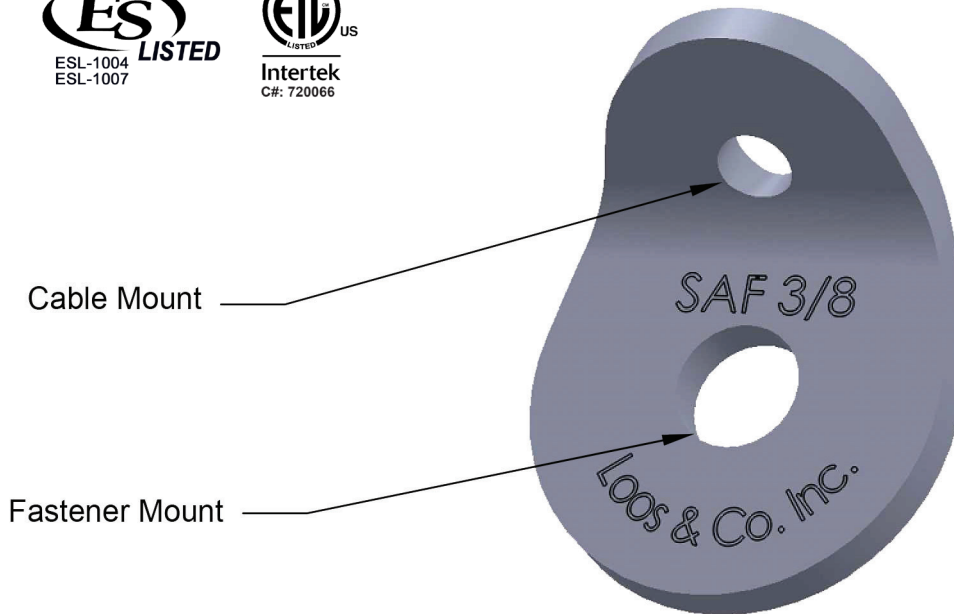

The SAF-3/8 is designed for use in attaching seismic cable bracing to steel, concrete, or wood structural members. The 3/8 inch (10mm) will accept lag bolts, bolts, and concrete anchors in both metric and imperial sizes. The cable mount will accept Gold, Orange, or Green cable.

Prying Factor			Prying Factor			Prying Factor		
Orientation 1			Orientation 2			Orientation 3		
Angle A	Angle B	Angle C	Angle D	Angle E	Angle F	Angle G	Angle H	Angle I
3.127	1.600	0.788	1.445	1.777	1.954	0.977	0.691	0.564

The SAF maintains the rated break strength of size #GO3 (gold), #OR4 (orange), and #GR6 (green) cable without the need for a thimble. The SAF may be used at both ends of the cable for anchoring equipment. SAFs are offered in 6 mounting sizes (SAF-1/4, SAF-3/8, SAF-1/2, SAF-5/8, SAF-3/4, and SAF-7/8).

UL Rated Load (lbs-f)	ICC-ES Breaking Strength (lbf)
1,900	1,700

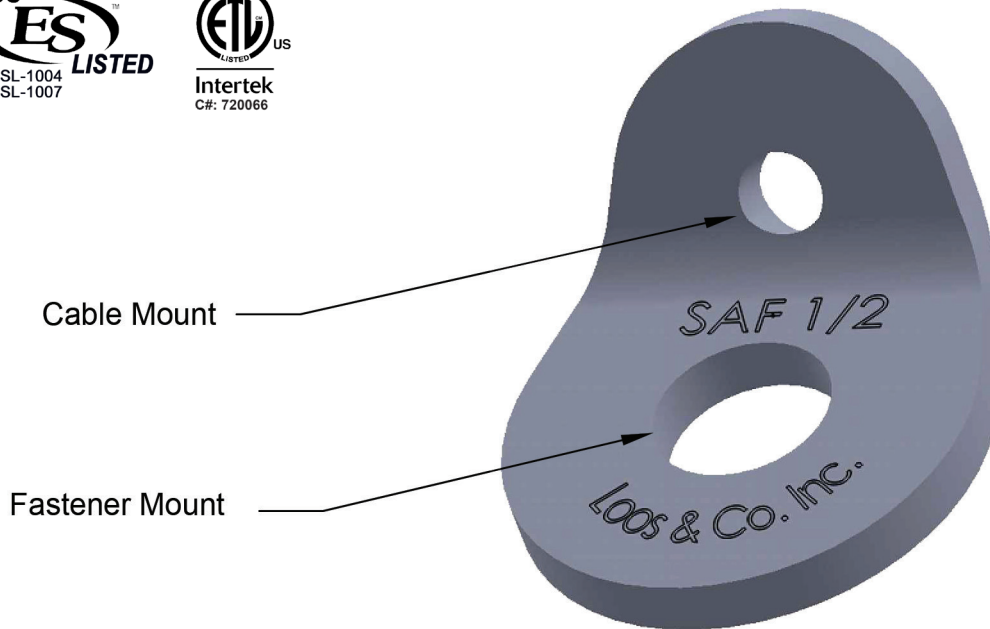

The SAF-1/2 is designed for use in attaching seismic cable bracing to steel, concrete, or wood structural members. The 1/2 inch (13mm) will accept lag bolts, bolts, and concrete anchors in both metric and imperial sizes. The cable mount will accept Gold, Orange, or Green cable.

Prying Factor			Prying Factor			Prying Factor		
Orientation 1			Orientation 2			Orientation 3		
Angle A	Angle B	Angle C	Angle D	Angle E	Angle F	Angle G	Angle H	Angle I
3.051	1.565	0.775	1.445	1.777	1.954	0.977	0.691	0.564

The SAF maintains the rated break strength of size #GO3 (gold), #OR4 (orange), and #GR6 (green) cable without the need for a thimble. The SAF may be used at both ends of the cable for anchoring equipment. SAFs are offered in 6 mounting sizes (SAF-1/4, SAF-3/8, SAF-1/2, SAF-5/8, SAF-3/4, and SAF-7/8).

UL Rated Load (lbs-f)	ICC-ES Breaking Strength (lbf)
1,900	1,700

SAF-5/8

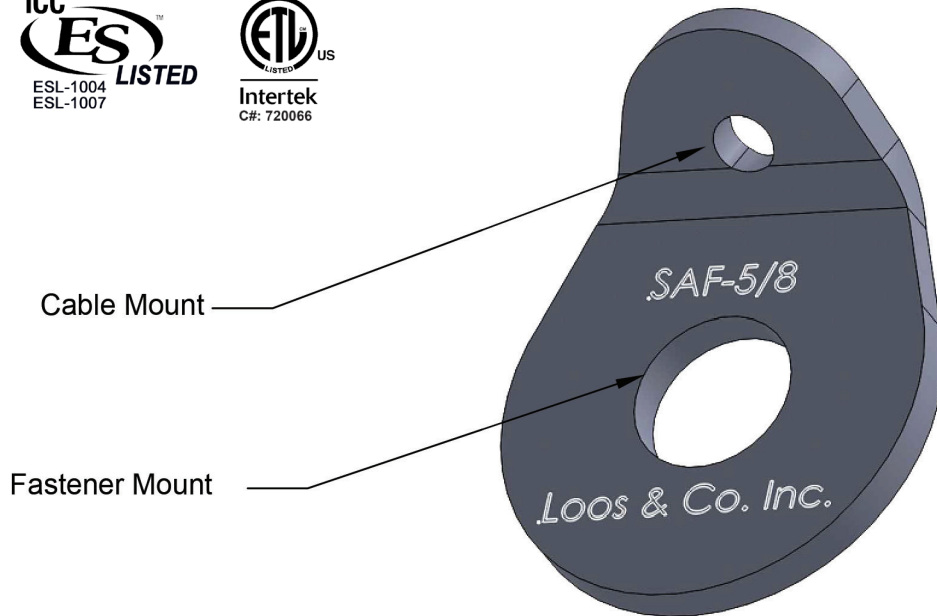

The SAF-5/8 is designed for use in attaching seismic cable bracing to steel, concrete, or wood structural members. The 5/8 inch (16mm) will accept lag bolts, bolts, and concrete anchors in both metric and imperial sizes. The cable mount will accept Gold, Orange, or Green cable.

Prying Factor		
Orientation 1		
Angle A	Angle B	Angle C
3.241	1.700	0.880

Prying Factor		
Orientation 2		
Angle D	Angle E	Angle F
1.698	1.960	2.099

Prying Factor		
Orientation 3		
Angle G	Angle H	Angle I
0.644	0.046	0.372

The SAF maintains the rated break strength of size #GO3 (gold), #OR4 (orange), and #GR6 (green) cable without the need for a thimble. The SAF may be used at both ends of the cable for anchoring equipment. SAFs are offered in 6 mounting sizes (SAF-1/4, SAF-3/8, SAF-1/2, SAF-5/8, SAF-3/4, and SAF-7/8).

UL Rated Load (lbs-f)	ICC-ES Breaking Strength (lbf)
1,900	4,200

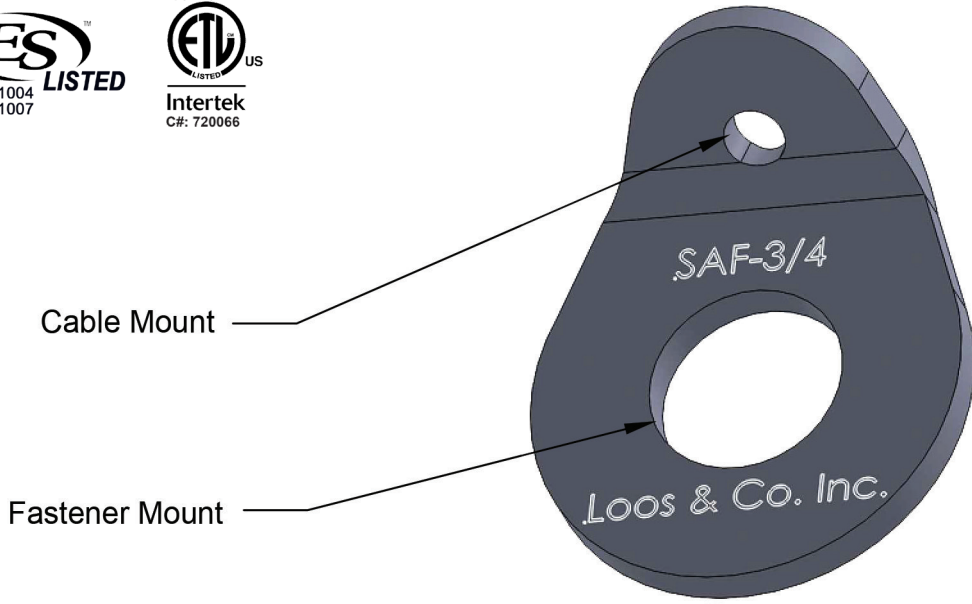

The SAF-3/4 is designed for use in attaching seismic cable bracing to steel, concrete, or wood structural members. The 3/4 inch (20mm) will accept lag bolts, bolts, and concrete anchors in both metric and imperial sizes. The cable mount will accept Gold, Orange, or Green cable.

Prying Factor		
Orientation 1		
Angle A	Angle B	Angle C
3.163	1.663	0.864

Prying Factor		
Orientation 2		
Angle D	Angle E	Angle F
1.698	1.960	2.099

Prying Factor		
Orientation 3		
Angle G	Angle H	Angle I
0.644	0.046	0.372

The SAF maintains the rated break strength of size #GO3 (gold), #OR4 (orange), and #GR6 (green) cable without the need for a thimble. The SAF may be used at both ends of the cable for anchoring equipment. SAFs are offered in 6 mounting sizes (SAF-1/4, SAF-3/8, SAF-1/2, SAF-5/8, SAF-3/4, and SAF-7/8).

UL Rated Load (lbs-f)	ICC-ES Breaking Strength (lbf)
1,900	4,200

SAF-7/8

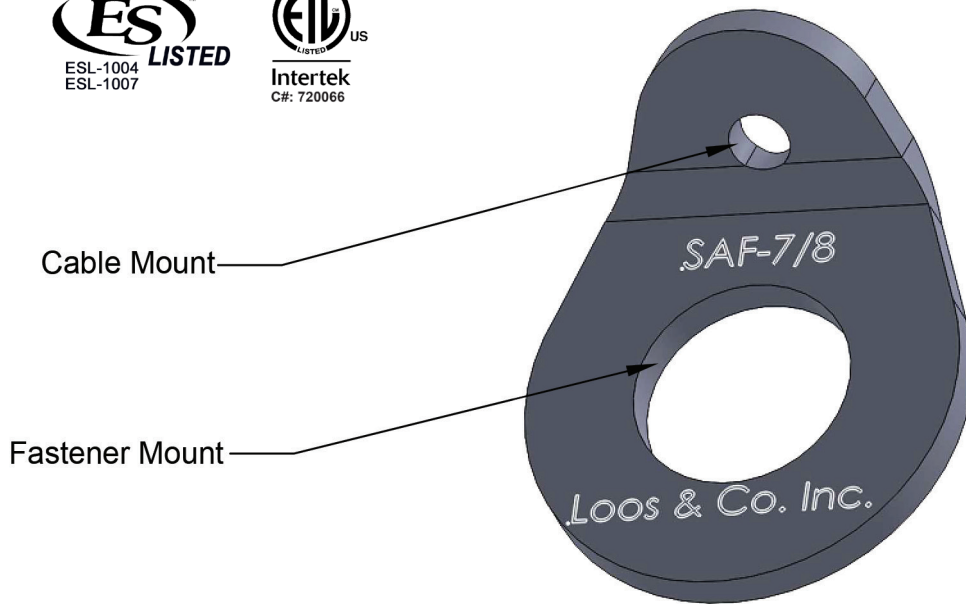

The SAF-7/8 is designed for use in attaching seismic cable bracing to steel, concrete, or wood structural members. The 7/8 inch (22mm) will accept lag bolts, bolts, and concrete anchors in both metric and imperial sizes. The cable mount will accept Gold, Orange, or Green cable.

Prying Factor			Prying Factor			Prying Factor		
Orientation 1			Orientation 2			Orientation 3		
Angle A	Angle B	Angle C	Angle D	Angle E	Angle F	Angle G	Angle H	Angle I
3.116	1.640	0.854	1.698	1.960	2.099	0.644	0.046	0.372

The SAF maintains the rated break strength of size #GO3 (gold), #OR4 (orange), and #GR6 (green) cable without the need for a thimble. The SAF may be used at both ends of the cable for anchoring equipment. SAFs are offered in 6 mounting sizes (SAF-1/4, SAF-3/8, SAF-1/2, SAF-5/8, SAF-3/4, and SAF-7/8).

UL Rated Load (lbs-f)	ICC-ES Breaking Strength (lbf)
1,900	4,200

SAFR Series

Seismic Anchoring Fitting Retrofit



SAFR-1/4

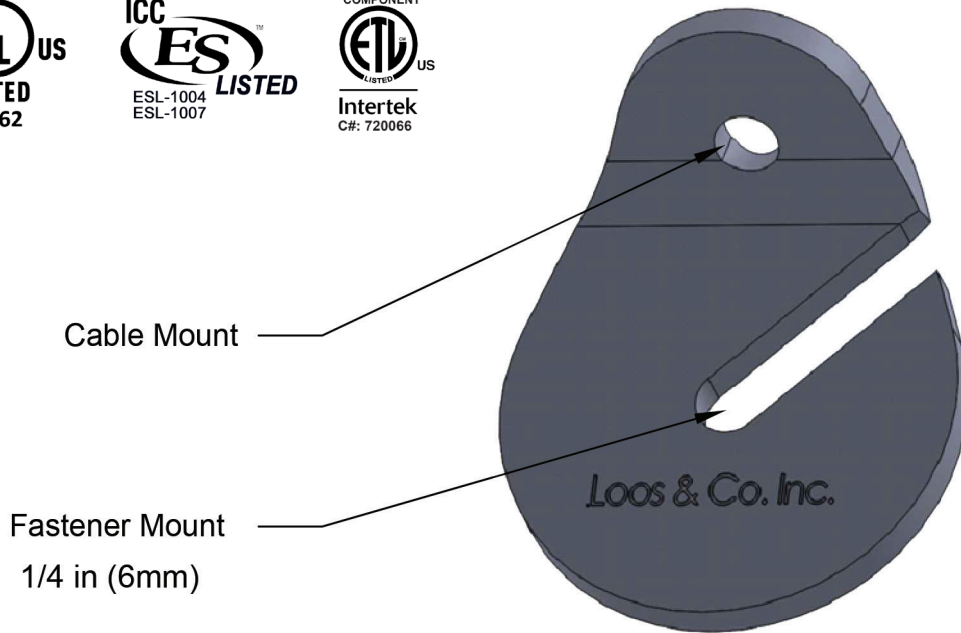

The SAFR-1/4 is designed as a retrofit Seismic Anchoring Fitting for use with pre-existing equipment and systems that require seismic bracing. The fitting is slotted to allow an existing fastener to be loosened, and the SAFR positioned without removal of the fastener. The cable mount will accept Gold or Orange cable.

Prying Factor		
Orientation 1		
Angle A	Angle B	Angle C
3.642	1.894	0.964

Prying Factor		
Orientation 2		
Angle D	Angle E	Angle F
1.698	1.960	2.099

Prying Factor		
Orientation 3		
Angle G	Angle H	Angle I
0.586	0.414	0.338

The SAFR maintains the rated break strength of size #GO3 (gold) or #OR4 (orange) cable without the need for a thimble. The SAFR may be used at both ends of the cable for anchoring equipment. SAFRs are offered in four mounting sizes (SAFR-1/4, SAFR-3/8, SAFR-1/2, and SAFR-5/8).

UL Rated Load (lbs-f)	ICC-ES Breaking Strength (lbf)
770	1,700

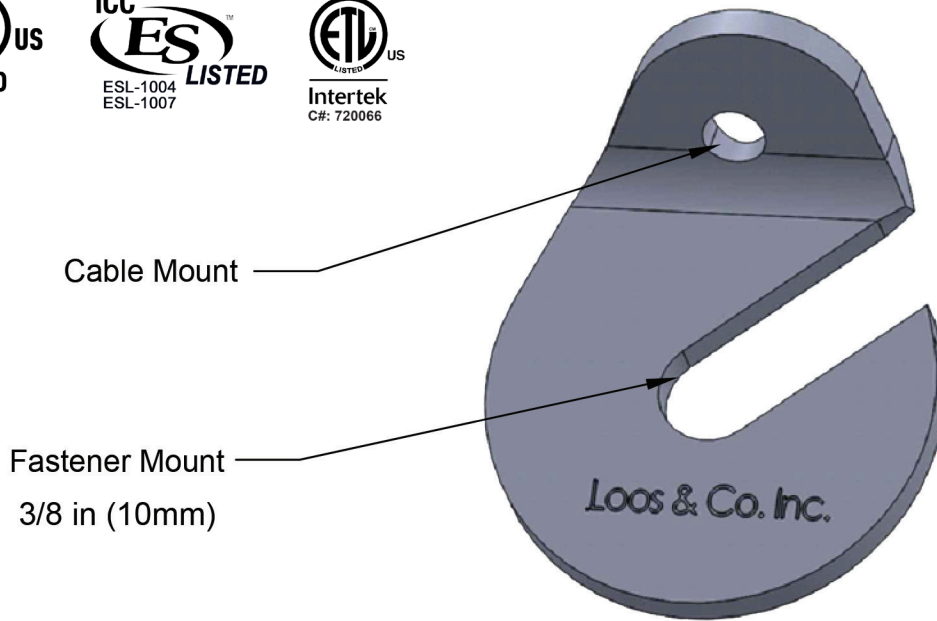

The SAFR-3/8 is designed as a retrofit Seismic Anchoring Fitting for use with pre-existing equipment and systems that require seismic bracing. The fitting is slotted to allow an existing fastener to be loosened, and the SAFR positioned without removal of the fastener. The cable mount will accept Gold or Orange cable.

Prying Factor		
Orientation 1		
Angle A	Angle B	Angle C
3.570	1.859	0.949

Prying Factor		
Orientation 2		
Angle D	Angle E	Angle F
1.698	1.960	2.099

Prying Factor		
Orientation 3		
Angle G	Angle H	Angle I
0.586	0.414	0.338

The SAFR maintains the rated break strength of size #GO3 (gold) or #OR4 (orange) cable without the need for a thimble. The SAFR may be used at both ends of the cable for anchoring equipment. SAFRs are offered in four mounting sizes (SAFR-1/4, SAFR-3/8, SAFR-1/2, and SAFR-5/8).

UL Rated Load (lbs-f)	ICC-ES Breaking Strength (lbf)
770	1,700

SAFR-1/2

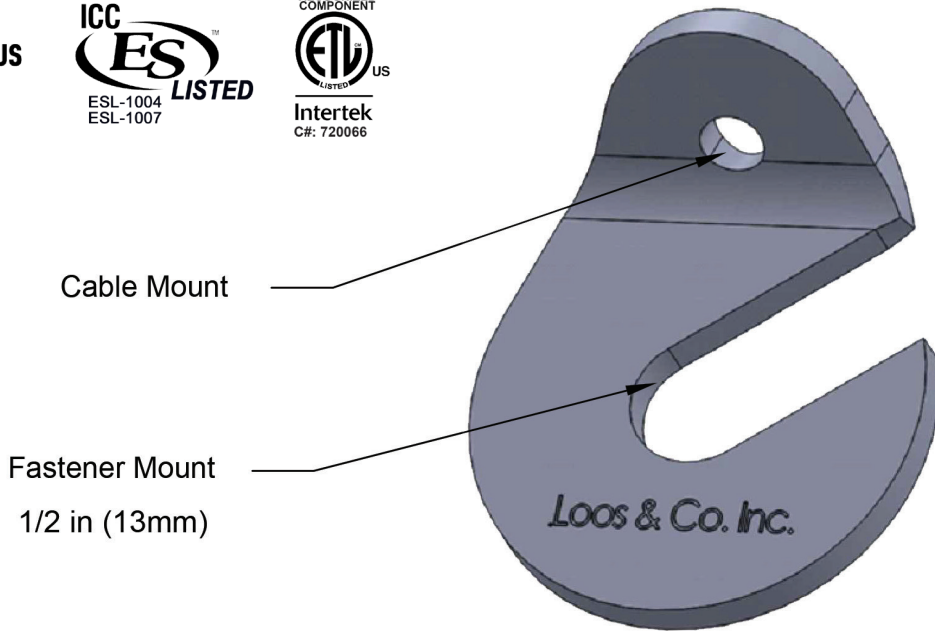

The SAFR-1/2 is designed as a retrofit Seismic Anchoring Fitting for use with pre-existing equipment and systems that require seismic bracing. The fitting is slotted to allow an existing fastener to be loosened, and the SAFR positioned without removal of the fastener. The cable mount will accept Gold or Orange cable.

Prying Factor		
Orientation 1		
Angle A	Angle B	Angle C
3.521	1.836	0.939

Prying Factor		
Orientation 2		
Angle D	Angle E	Angle F
1.698	1.960	2.099

Prying Factor		
Orientation 3		
Angle G	Angle H	Angle I
0.586	0.414	0.338

The SAFR maintains the rated break strength of size #GO3 (gold) or #OR4 (orange) cable without the need for a thimble. The SAFR may be used at both ends of the cable for anchoring equipment. SAFRs are offered in four mounting sizes (SAFR-1/4, SAFR-3/8, SAFR-1/2, and SAFR-5/8).

UL Rated Load (lbs-f)	ICC-ES Breaking Strength (lbf)
770	1,700

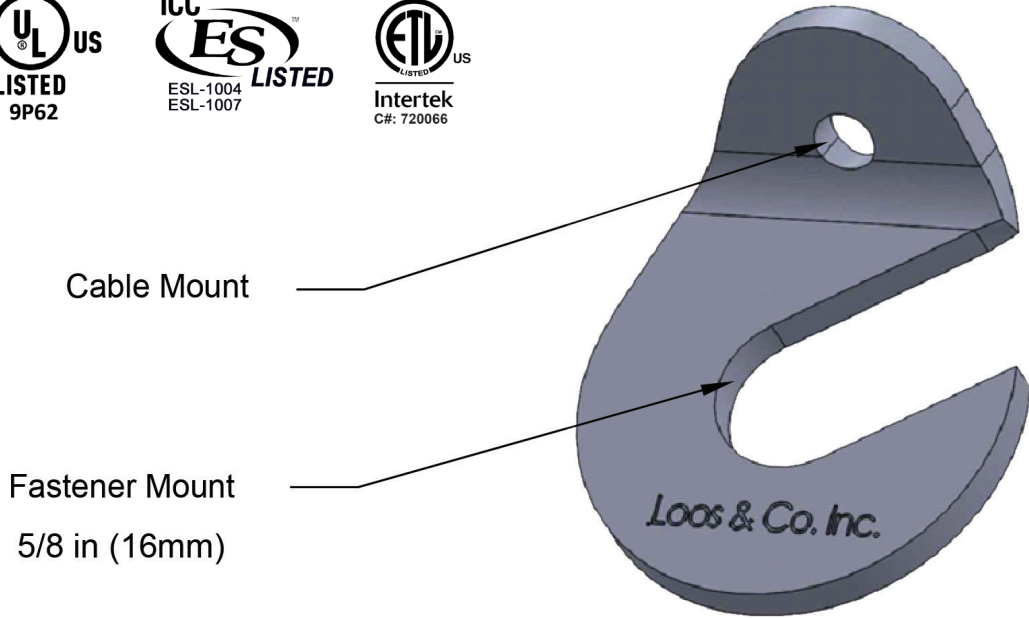

The SAFR-5/8 is designed as a retrofit Seismic Anchoring Fitting for use with pre-existing equipment and systems that require seismic bracing. The fitting is slotted to allow an existing fastener to be loosened, and the SAFR positioned without removal of the fastener. The cable mount will accept Gold or Orange cable.

Prying Factor		
Orientation 1		
Angle A	Angle B	Angle C
3.497	1.809	0.927

Prying Factor		
Orientation 2		
Angle D	Angle E	Angle F
1.698	1.960	2.099

Prying Factor		
Orientation 3		
Angle G	Angle H	Angle I
0.586	0.414	0.338

The SAFR maintains the rated break strength of size #GO3 (gold) or #OR4 (orange) cable without the need for a thimble. The SAFR may be used at both ends of the cable for anchoring equipment. SAFRs are offered in four mounting sizes (SAFR-1/4, SAFR-3/8, SAFR-1/2, and SAFR-5/8).

UL Rated Load (lbs-f)	ICC-ES Breaking Strength (lbf)
770	1,700

SAF2 Series

Seismic Anchoring Fitting - 2-Way

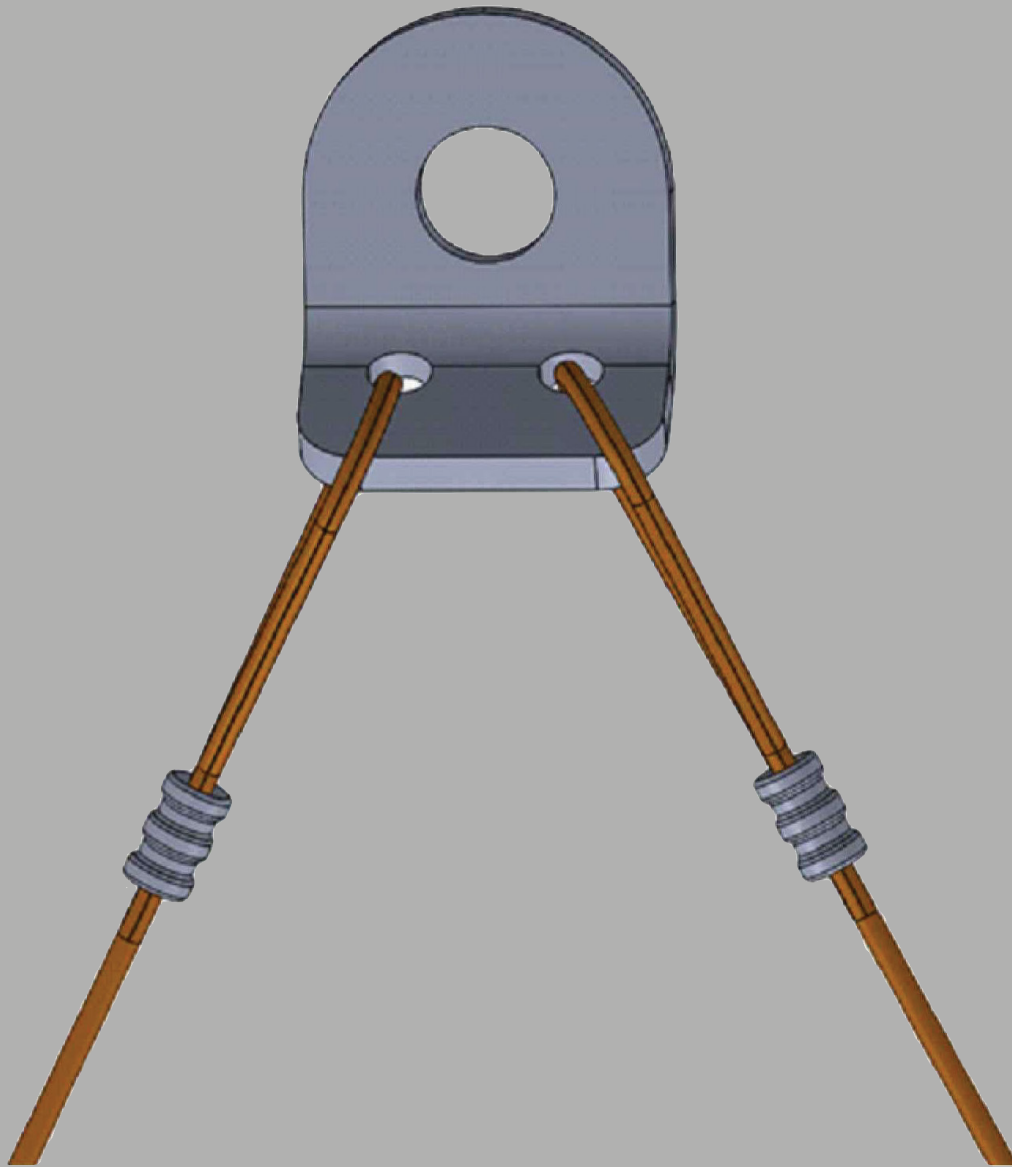

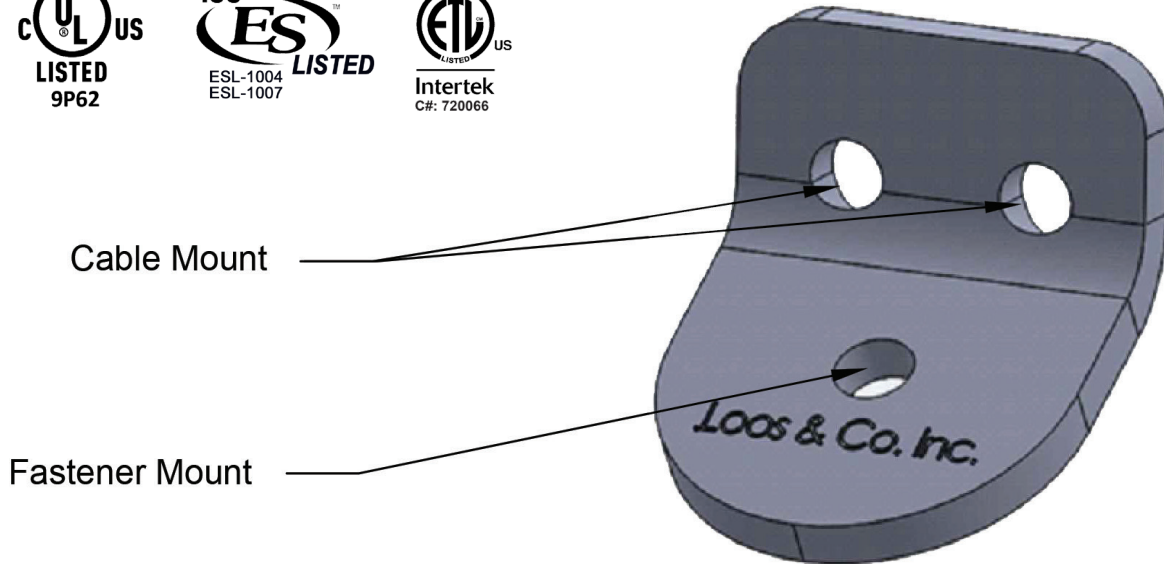

The SAF2-1/4 is designed for use in attaching seismic cable bracing to cable trays, HVAC equipment, clevis hangers, sprinkler systems, and trapeze supports for attachment to a steel, concrete, or wood structural member. The 1/4" (6mm) fastener mounting hole will accept lag bolts, bolts, threaded rod, and concrete anchors in both metric and imperial sizes. The two cable mounts will accept Gold, Orange, or Green cable, and are ideal for 2-way bracing.

Prying Factor		
Orientation 1		
Angle A	Angle B	Angle C
3.259	1.659	0.879

Prying Factor		
Orientation 2		
Angle D	Angle E	Angle F
1.445	1.777	1.954

Prying Factor		
Orientation 3		
Angle G	Angle H	Angle I
0.977	0.691	0.564

The SAF2 maintains the rated break strength of size #GO3 (gold), #OR4 (orange), and #GR6 (green) cable without the need for a thimble. The SAF2 may be used at both ends of the cable for anchoring equipment. SAF2s are offered in six mounting sizes (SAF2-1/4, SAF2-3/8, SAF2-1/2, SAF2-5/8, SAF2-3/4, and SAF2-7/8).

UL Rated Load (lbs-f)	ICC-ES Breaking Strength (lbf)
1,900	1,700

SAF2-3/8

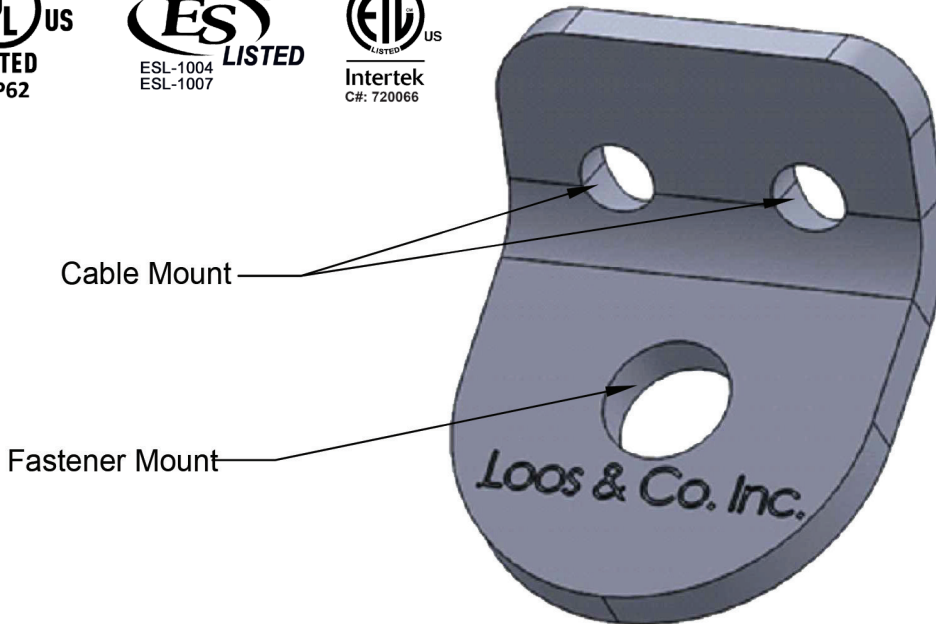

The SAF2-3/8 is designed for use in attaching seismic cable bracing to cable trays, HVAC equipment, clevis hangers, sprinkler systems, and trapeze supports for attachment to a steel, concrete, or wood structural member. The 3/8" (10mm) fastener mounting hole will accept lag bolts, bolts, threaded rod, and concrete anchors in both metric and imperial sizes. The two cable mounts will accept Gold, Orange, or Green cable, and are ideal for 2-way bracing.

Prying Factor		
Orientation 1		
Angle A	Angle B	Angle C
3.127	1.600	0.788

Prying Factor		
Orientation 2		
Angle D	Angle E	Angle F
1.445	1.777	1.954

Prying Factor		
Orientation 3		
Angle G	Angle H	Angle I
0.977	0.691	0.564

The SAF2 maintains the rated break strength of size #GO3 (gold), #OR4 (orange), and #GR6 (green) cable without the need for a thimble. The SAF2 may be used at both ends of the cable for anchoring equipment. SAF2s are offered in six mounting sizes (SAF2-1/4, SAF2-3/8, SAF2-1/2, SAF2-5/8, SAF2-3/4, and SAF2-7/8).

UL Rated Load (lbs-f)	ICC-ES Breaking Strength (lbf)
1,900	1,700

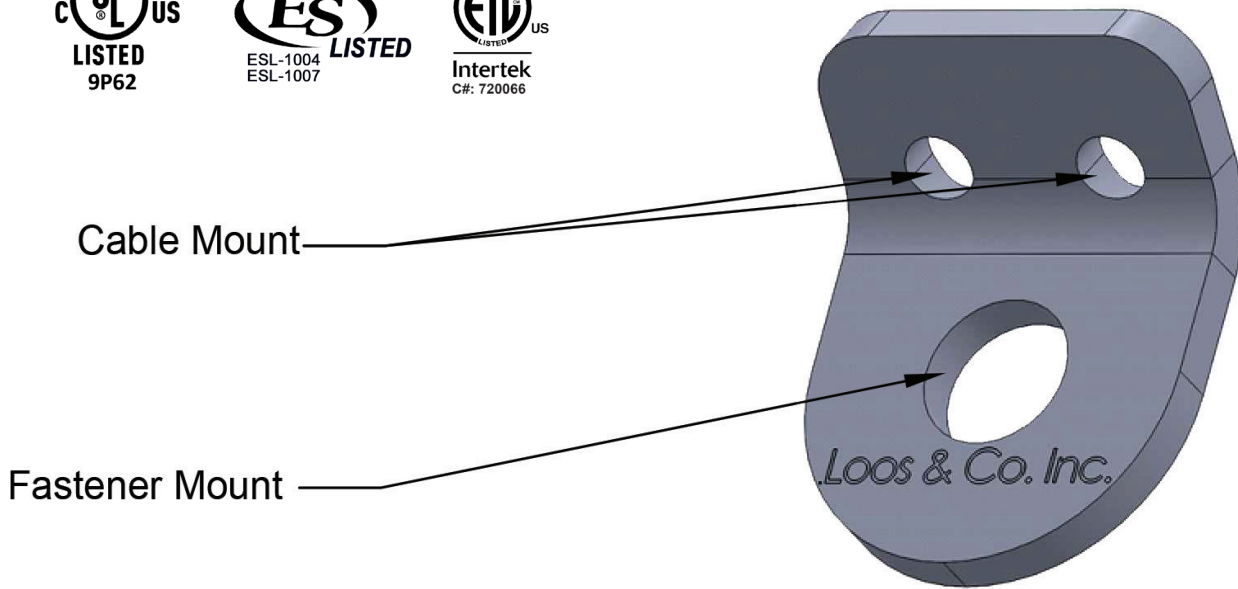

The SAF2-1/2 is designed for use in attaching seismic cable bracing to cable trays, HVAC equipment, clevis hangers, sprinkler systems, and trapeze supports for attachment to a steel, concrete, or wood structural member. The 1/2" (13mm) fastener mounting hole will accept lag bolts, bolts, threaded rod, and concrete anchors in both metric and imperial sizes. The two cable mounts will accept Gold, Orange, or Green cable, and are ideal for 2-way bracing.

Prying Factor		
Orientation 1		
Angle A	Angle B	Angle C
3.051	1.565	0.775

Prying Factor		
Orientation 2		
Angle D	Angle E	Angle F
1.445	1.777	1.954

Prying Factor		
Orientation 3		
Angle G	Angle H	Angle I
0.977	0.691	0.564

The SAF2 maintains the rated break strength of size #GO3 (gold), #OR4 (orange), and #GR6 (green) cable without the need for a thimble. The SAF2 may be used at both ends of the cable for anchoring equipment. SAF2s are offered in six mounting sizes (SAF2-1/4, SAF2-3/8, SAF2-1/2, SAF2-5/8, SAF2-3/4, and SAF2-7/8).

UL Rated Load (lbs-f)	ICC-ES Breaking Strength (lbf)
1,900	1,700

SAF2-5/8

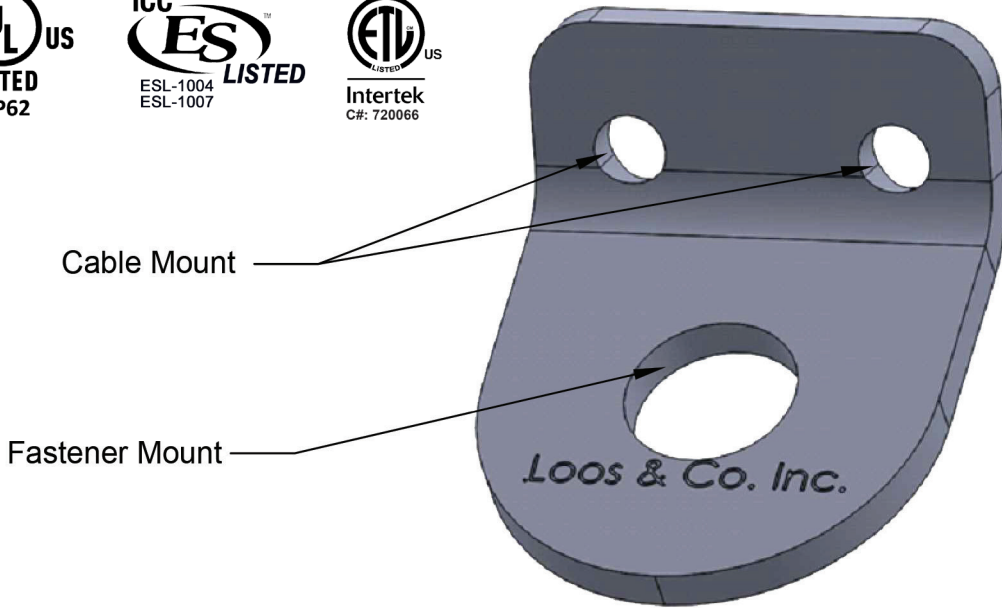

The SAF2-5/8 is designed for use in attaching seismic cable bracing to cable trays, HVAC equipment, clevis hangers, sprinkler systems, and trapeze supports for attachment to a steel, concrete, or wood structural member. The 5/8" (16mm) fastener mounting hole will accept lag bolts, bolts, threaded rod, and concrete anchors in both metric and imperial sizes. The two cable mounts will accept Gold, Orange, or Green cable, and are ideal for 2-way bracing.

Prying Factor		
Orientation 1		
Angle A	Angle B	Angle C
3.241	1.700	0.880

Prying Factor		
Orientation 2		
Angle D	Angle E	Angle F
1.698	1.960	2.099

Prying Factor		
Orientation 3		
Angle G	Angle H	Angle I
0.644	0.046	0.372

The SAF2 maintains the rated break strength of size #GO3 (gold), #OR4 (orange), and #GR6 (green) cable without the need for a thimble. The SAF2 may be used at both ends of the cable for anchoring equipment. SAF2s are offered in six mounting sizes (SAF2-1/4, SAF2-3/8, SAF2-1/2, SAF2-5/8, SAF2-3/4, and SAF2-7/8).

UL Rated Load (lbs-f)	ICC-ES Breaking Strength (lbf)
1,900	4,200

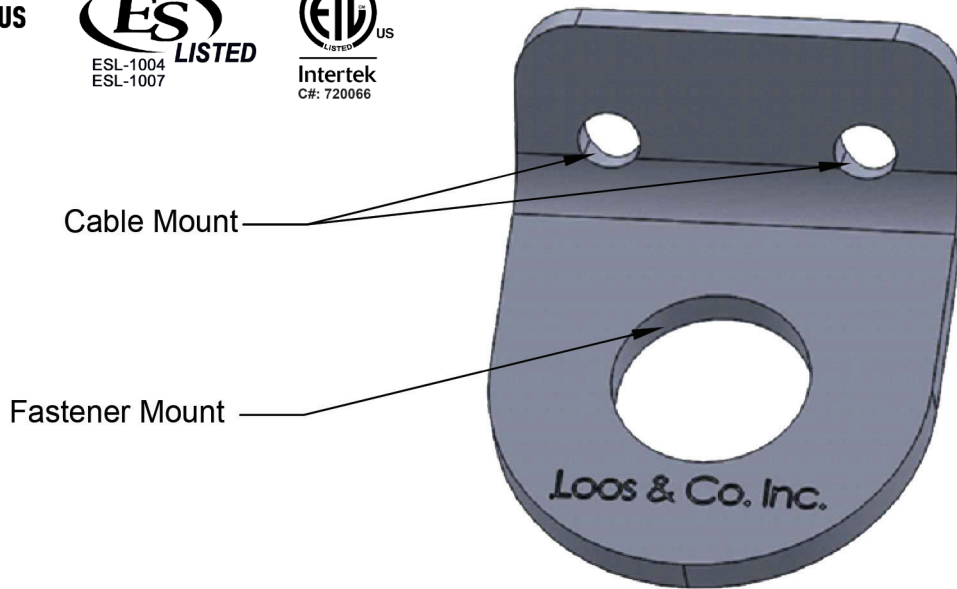

The SAF2-3/4 is designed for use in attaching seismic cable bracing to cable trays, HVAC equipment, clevis hangers, sprinkler systems, and trapeze supports for attachment to a steel, concrete, or wood structural member. The 3/4" (20mm) fastener mounting hole will accept lag bolts, bolts, threaded rod, and concrete anchors in both metric and imperial sizes. The two cable mounts will accept Gold, Orange, or Green cable, and are ideal for 2-way bracing.

Prying Factor		
Orientation 1		
Angle A	Angle B	Angle C
3.163	1.663	0.864

Prying Factor		
Orientation 2		
Angle D	Angle E	Angle F
1.698	1.960	2.099

Prying Factor		
Orientation 3		
Angle G	Angle H	Angle I
0.644	0.455	0.372

The SAF2 maintains the rated break strength of size #GO3 (gold), #OR4 (orange), and #GR6 (green) cable without the need for a thimble. The SAF2 may be used at both ends of the cable for anchoring equipment. SAF2s are offered in six mounting sizes (SAF2-1/4, SAF2-3/8, SAF2-1/2, SAF2-5/8, SAF2-3/4, and SAF2-7/8).

UL Rated Load (lbs-f)	ICC-ES Breaking Strength (lbf)
1,900	4,200

SAF2-7/8

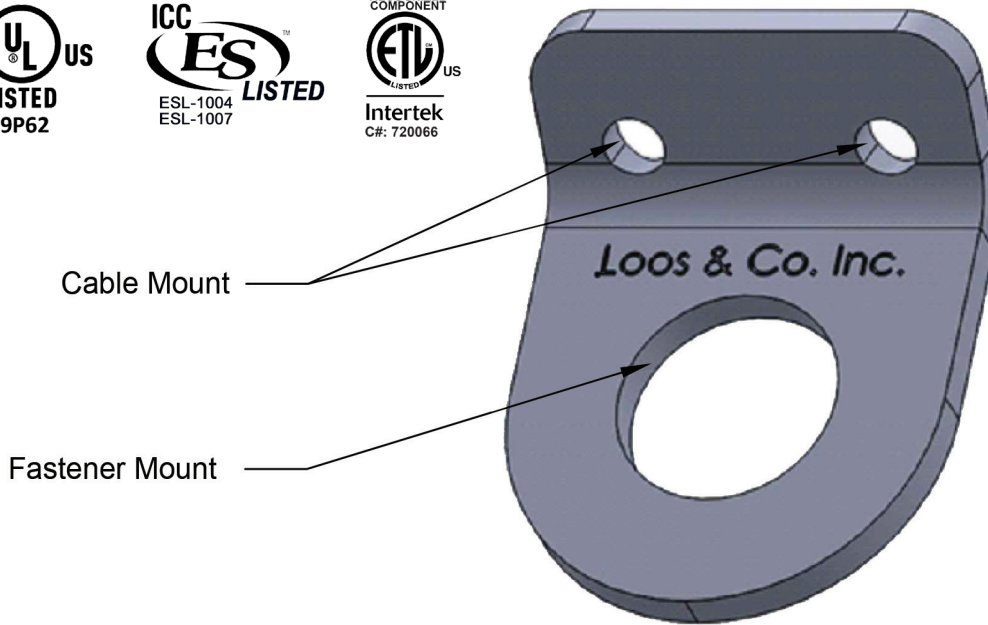

The SAF2-7/8 is designed for use in attaching seismic cable bracing to cable trays, HVAC equipment, clevis hangers, sprinkler systems, and trapeze supports for attachment to a steel, concrete, or wood structural member. The 7/8" (22mm) fastener mounting hole will accept lag bolts, bolts, threaded rod, and concrete anchors in both metric and imperial sizes. The two cable mounts will accept Gold, Orange, or Green cable, and are ideal for 2-way bracing.

Prying Factor		
Orientation 1		
Angle A	Angle B	Angle C
3.116	1.640	0.854

Prying Factor		
Orientation 2		
Angle D	Angle E	Angle F
1.698	1.960	2.099

Prying Factor		
Orientation 3		
Angle G	Angle H	Angle I
0.644	0.455	0.372

The SAF2 maintains the rated break strength of size #GO3 (gold), #OR4 (orange), and #GR6 (green) cable without the need for a thimble. The SAF2 may be used at both ends of the cable for anchoring equipment. SAF2s are offered in six mounting sizes (SAF2-1/4, SAF2-3/8, SAF2-1/2, SAF2-5/8, SAF2-3/4, and SAF2-7/8).

UL Rated Load (lbs-f)	ICC-ES Breaking Strength (lbf)
1,900	4,200

SAF2R Series

**Seismic Anchoring Fitting
Retrofit - 2-Way**

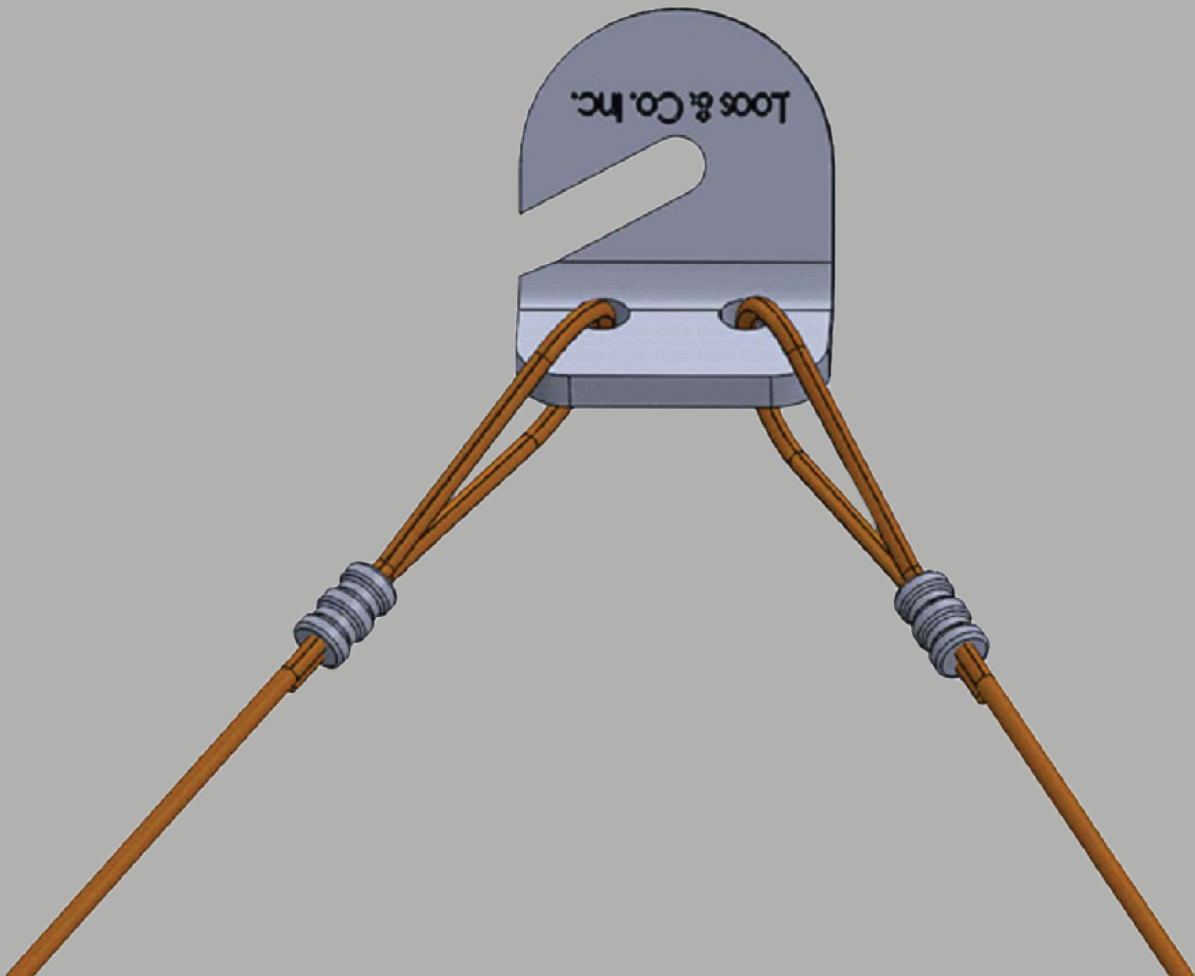

SAF2R-1/4

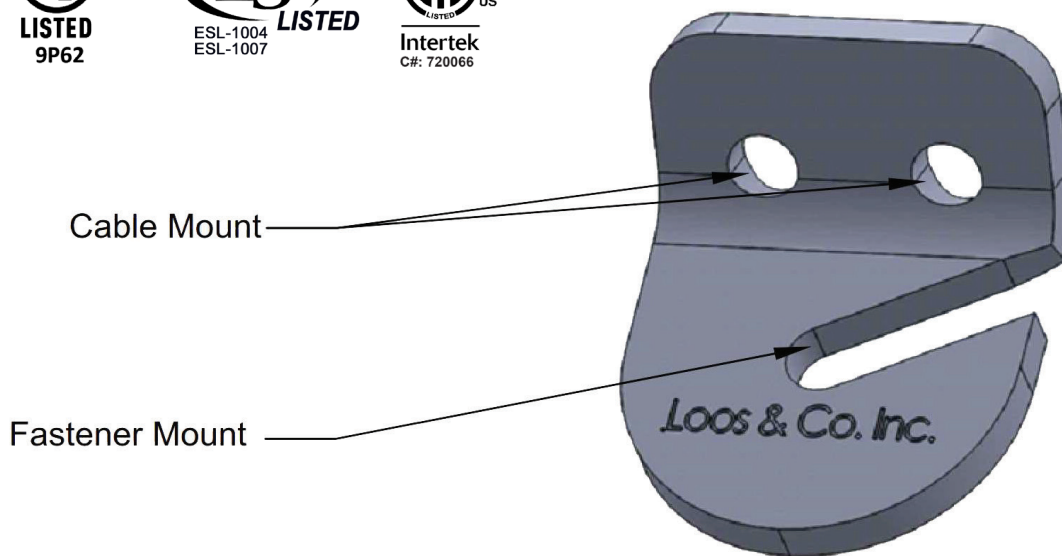

The SAF2R-1/4 is designed for use in attaching seismic cable bracing to cable trays, HVAC equipment, clevis hangers, sprinkler systems, and trapeze supports in a retrofit environment. The fitting is slotted to allow an existing fastener to be loosened, and the SAF2R positioned without removal of the fastener. The 1/4" (6mm) fastener mounting hole will accept lag bolts, bolts, threaded rod, and concrete anchors in both metric and imperial sizes. The two cable mounts will accept Gold or Orange cable, and are ideal for 2-way bracing.

Prying Factor		
Orientation 1		
Angle A	Angle B	Angle C
3.642	1.894	0.964

Prying Factor		
Orientation 2		
Angle D	Angle E	Angle F
1.698	1.960	2.099

Prying Factor		
Orientation 3		
Angle G	Angle H	Angle I
0.586	0.414	0.338

The SAF2R maintains the rated break strength of size #GO3 (gold) and #OR4 (orange) cable without the need for a thimble. The SAF2R may be used at both ends of the cable for anchoring equipment. SAF2Rs are offered in four mounting sizes (SAF2R-1/4, SAF2R-3/8, SAF2R-1/2, and SAF2R-5/8).

UL Rated Load (lbs-f)	ICC-ES Breaking Strength (lbf)
770	1,700

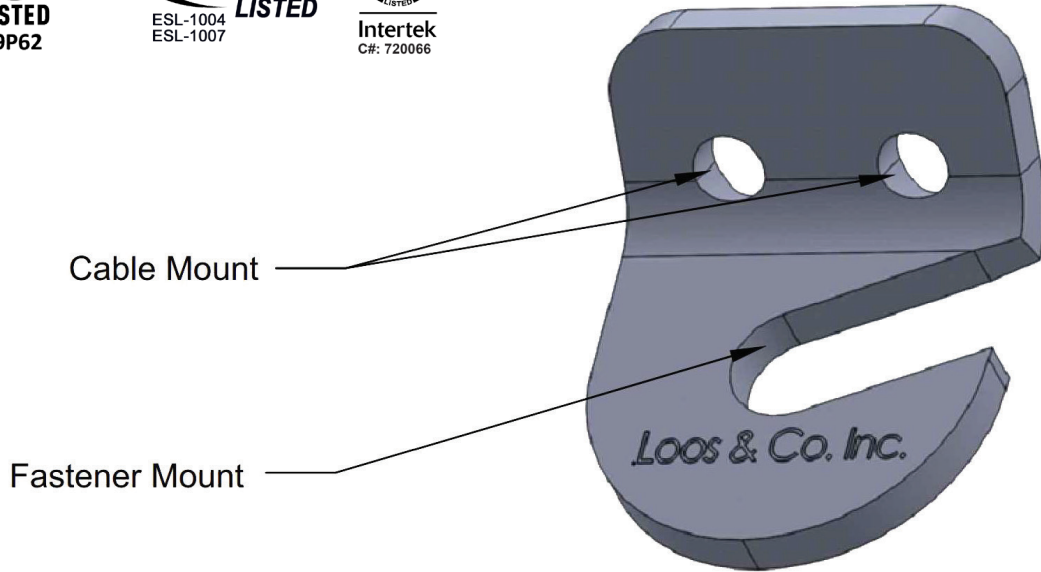

The SAF2R-3/8 is designed for use in attaching seismic cable bracing to cable trays, HVAC equipment, clevis hangers, sprinkler systems, and trapeze supports in a retrofit environment. The fitting is slotted to allow an existing fastener to be loosened, and the SAF2R positioned without removal of the fastener. The 3/8" (10mm) fastener mounting hole will accept lag bolts, bolts, threaded rod, and concrete anchors in both metric and imperial sizes. The two cable mounts will accept Gold or Orange cable, and are ideal for 2-way bracing.

Prying Factor		
Orientation 1		
Angle A	Angle B	Angle C
3.570	1.859	0.949

Prying Factor		
Orientation 2		
Angle D	Angle E	Angle F
1.698	1.960	2.099

Prying Factor		
Orientation 3		
Angle G	Angle H	Angle I
0.586	0.414	0.338

The SAF2R maintains the rated break strength of size #GO3 (gold) and #OR4 (orange) cable without the need for a thimble. The SAF2R may be used at both ends of the cable for anchoring equipment. SAF2Rs are offered in four mounting sizes (SAF2R-1/4, SAF2R-3/8, SAF2R-1/2, and SAF2R-5/8).

UL Rated Load (lbs-f)	ICC-ES Breaking Strength (lbf)
770	1,700

SAF2R-1/2

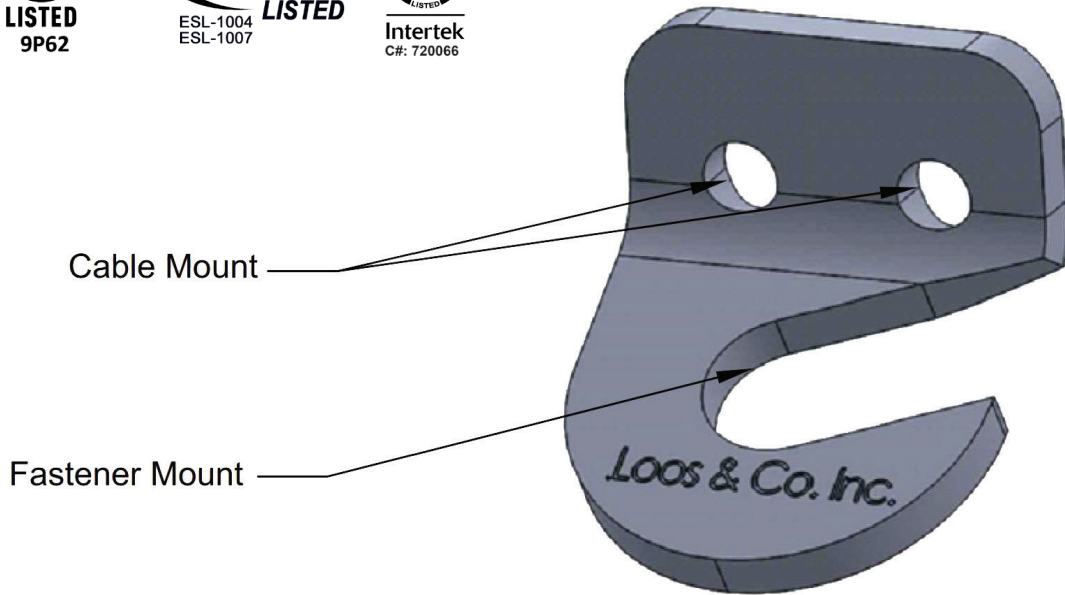

The SAF2R-1/2 is designed for use in attaching seismic cable bracing to cable trays, HVAC equipment, clevis hangers, sprinkler systems, and trapeze supports in a retrofit environment. The fitting is slotted to allow an existing fastener to be loosened, and the SAF2R positioned without removal of the fastener. The 1/2" (13mm) fastener mounting hole will accept lag bolts, bolts, threaded rod, and concrete anchors in both metric and imperial sizes. The two cable mounts will accept Gold or Orange cable, and are ideal for 2-way bracing.

Prying Factor		
Orientation 1		
Angle A	Angle B	Angle C
3.521	1.836	0.939

Prying Factor		
Orientation 2		
Angle D	Angle E	Angle F
1.698	1.960	2.099

Prying Factor		
Orientation 3		
Angle G	Angle H	Angle I
0.586	0.414	0.338

The SAF2R maintains the rated break strength of size #GO3 (gold) and #OR4 (orange) cable without the need for a thimble. The SAF2R may be used at both ends of the cable for anchoring equipment. SAF2Rs are offered in four mounting sizes (SAF2R-1/4, SAF2R-3/8, SAF2R-1/2, and SAF2R-5/8).

UL Rated Load (lbs-f)	ICC-ES Breaking Strength (lbf)
770	1,700

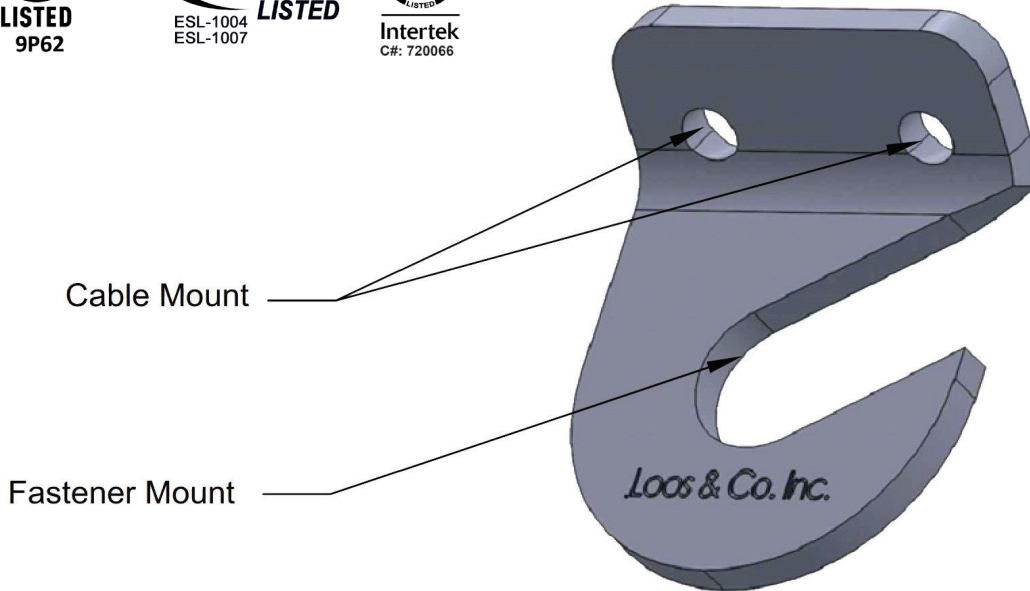

The SAF2R-5/8 is designed for use in attaching seismic cable bracing to cable trays, HVAC equipment, clevis hangers, sprinkler systems, and trapeze supports in a retrofit environment. The fitting is slotted to allow an existing fastener to be loosened, and the SAF2R positioned without removal of the fastener. The 5/8" (16mm) fastener mounting hole will accept lag bolts, bolts, threaded rod, and concrete anchors in both metric and imperial sizes. The two cable mounts will accept Gold or Orange cable, and are ideal for 2-way bracing.

Prying Factor		
Orientation 1		
Angle A	Angle B	Angle C
3.467	1.809	0.927

Prying Factor		
Orientation 2		
Angle D	Angle E	Angle F
1.698	1.960	2.099

Prying Factor		
Orientation 3		
Angle G	Angle H	Angle I
0.586	0.414	0.338

The SAF2R maintains the rated break strength of size #GO3 (gold) and #OR4 (orange) cable without the need for a thimble. The SAF2R may be used at both ends of the cable for anchoring equipment. SAF2Rs are offered in four mounting sizes (SAF2R-1/4, SAF2R-3/8, SAF2R-1/2, and SAF2R-5/8).

UL Rated Load (lbs-f)	ICC-ES Breaking Strength (lbf)
770	1,700

LPF Series

Low-Pry Fitting

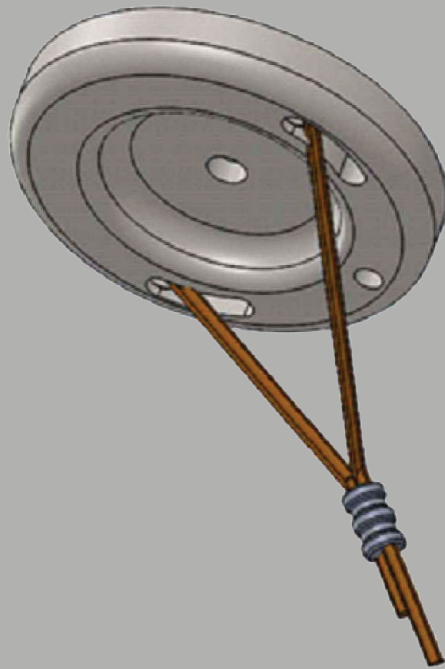
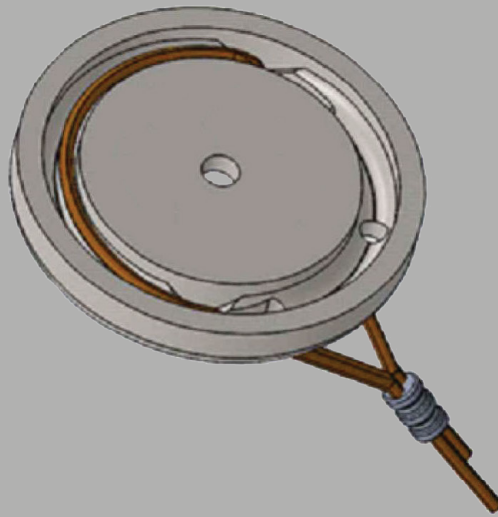



LPF Installation

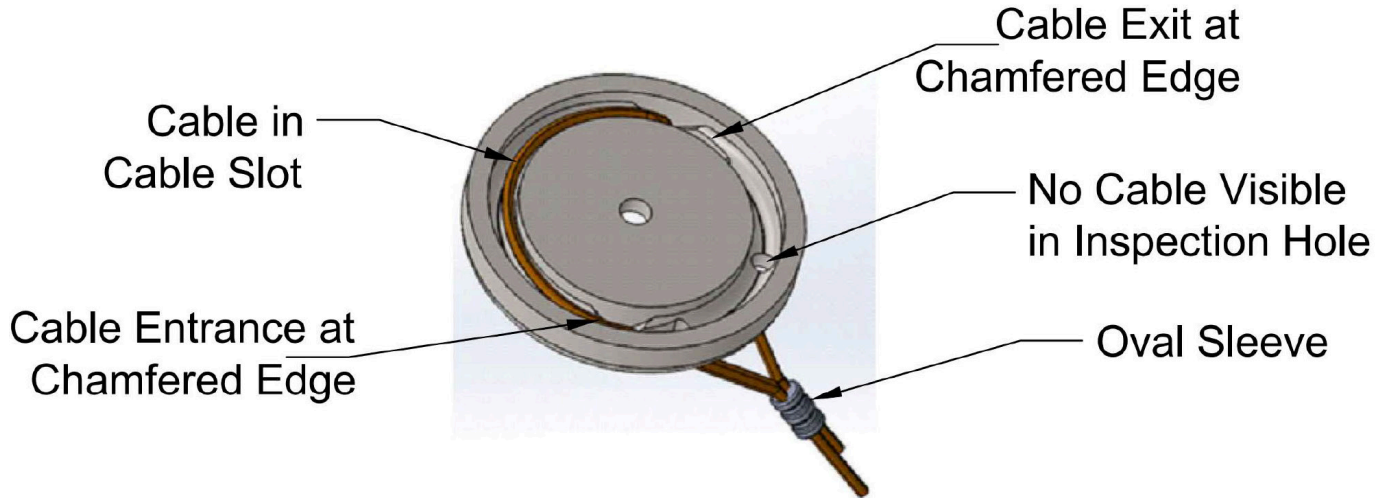

The Low-Pry Fitting (LPF), due to its design, offers a low prying effect. The cable is inserted into the slot provided, at the chamfered edge, through the cable slot and out the cable exit. The cable is then secured with the proper size oval sleeve. To ensure that the cable is properly installed, no cable should be visible through the inspection hole (opposite the proper cable slot). The LPF should be mounted with the inspection hole pointed in the direction of the brace. The cable mount will accept Gold, Orange, and Green cable.

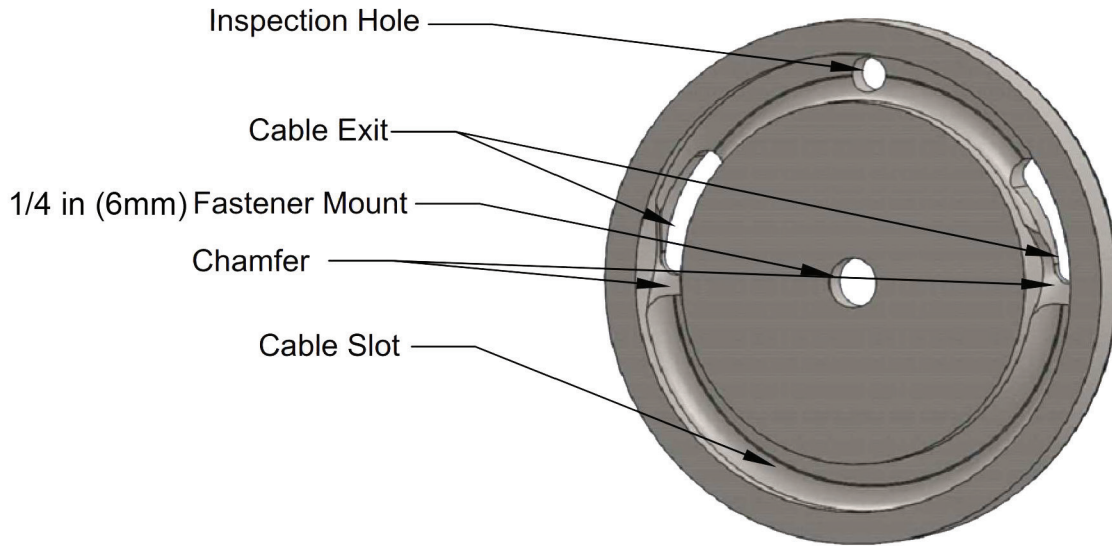

The LPF-1/4 is specifically designed to reduce the prying effect on fasteners. The cable is nested in the groove provided, and exits through two chamfered slots (to prevent damage to the outer fibers of the cable). An inspection hole is provided to ensure that the cable is placed in the correct position within the groove. The LPF has the lowest prying factor yet to be achieved. The cable mount will accept Gold, Orange, and Green cable.

Prying Factor		
Orientation 1		
Angle A	Angle B	Angle C
1.627	0.833	0.410

Prying Factor		
Orientation 2		
Angle D	Angle E	Angle F
0.673	0.818	0.895

Prying Factor		
Orientation 3		
Angle G	Angle H	Angle I
0.500	0.354	0.289

UL Rated Load (lbs-f)	ICC-ES Breaking Strength (lbf)
1,900	1,700

LPF-3/8

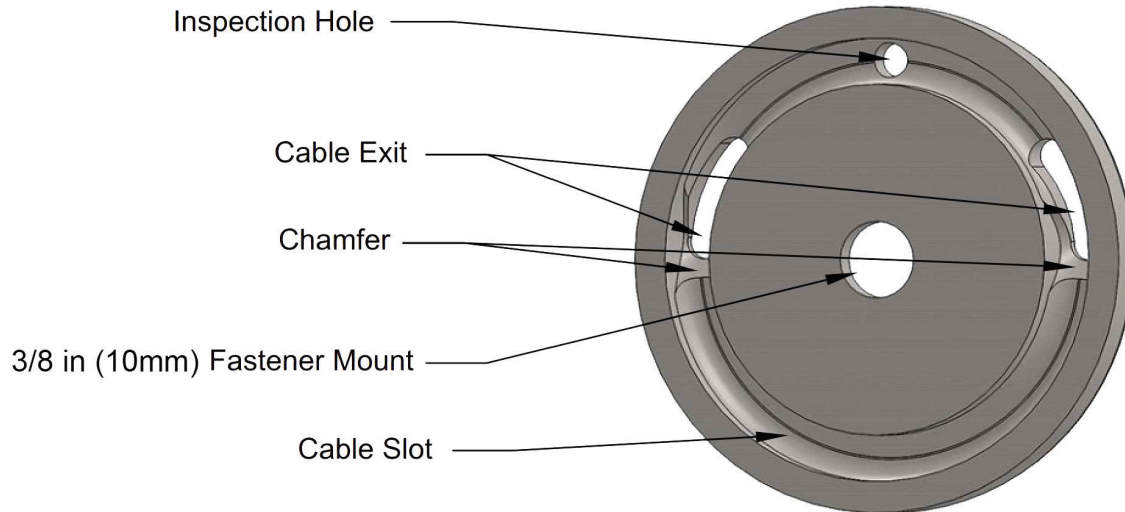

The LPF-3/8 is specifically designed to reduce the prying effect on fasteners. The cable is nested in the groove provided, and exits through two chamfered slots (to prevent damage to the outer fibers of the cable). An inspection hole is provided to ensure that the cable is placed in the correct position within the groove. The LPF has the lowest prying factor yet to be achieved. The cable mount will accept Gold, Orange, and Green cable.

Prying Factor		
Orientation 1		
Angle A	Angle B	Angle C
1.634	0.839	0.417

Prying Factor		
Orientation 2		
Angle D	Angle E	Angle F
0.673	0.818	0.895

Prying Factor		
Orientation 3		
Angle G	Angle H	Angle I
0.500	0.354	0.289

UL Rated Load (lbs-f)	ICC-ES Breaking Strength (lbf)
1,900	1,700

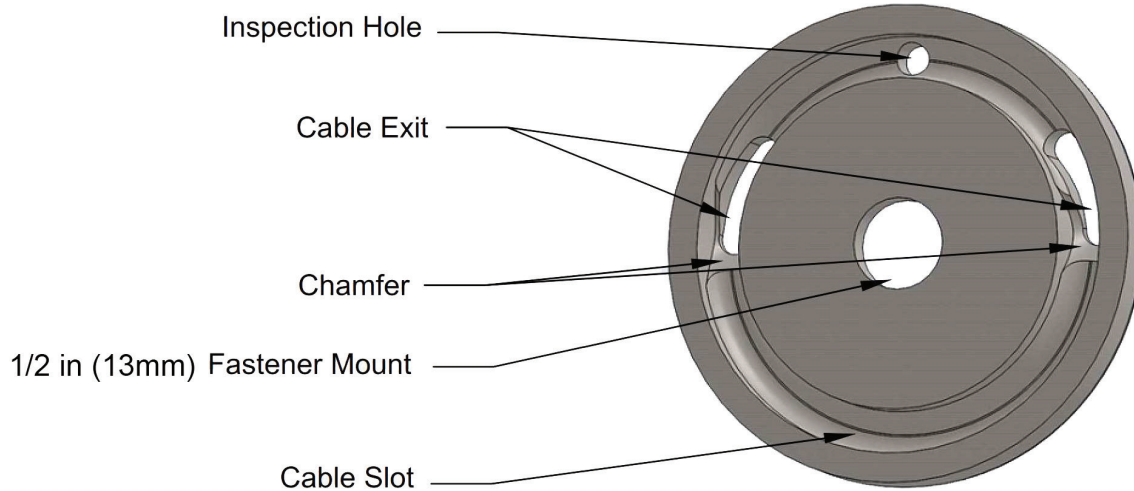

The LPF-1/2 is specifically designed to reduce the prying effect on fasteners. The cable is nested in the groove provided, and exits through two chamfered slots (to prevent damage to the outer fibers of the cable). An inspection hole is provided to ensure that the cable is placed in the correct position within the groove. The LPF has the lowest prying factor yet to be achieved. The cable mount will accept Gold, Orange, and Green cable.

Prying Factor		
Orientation 1		
Angle A	Angle B	Angle C
1.640	0.846	0.423

Prying Factor		
Orientation 2		
Angle D	Angle E	Angle F
0.673	0.818	0.895

Prying Factor		
Orientation 3		
Angle G	Angle H	Angle I
0.500	0.354	0.289

UL Rated Load (lbs-f)	ICC-ES Breaking Strength (lbf)
1,900	1,700

LPF-5/8

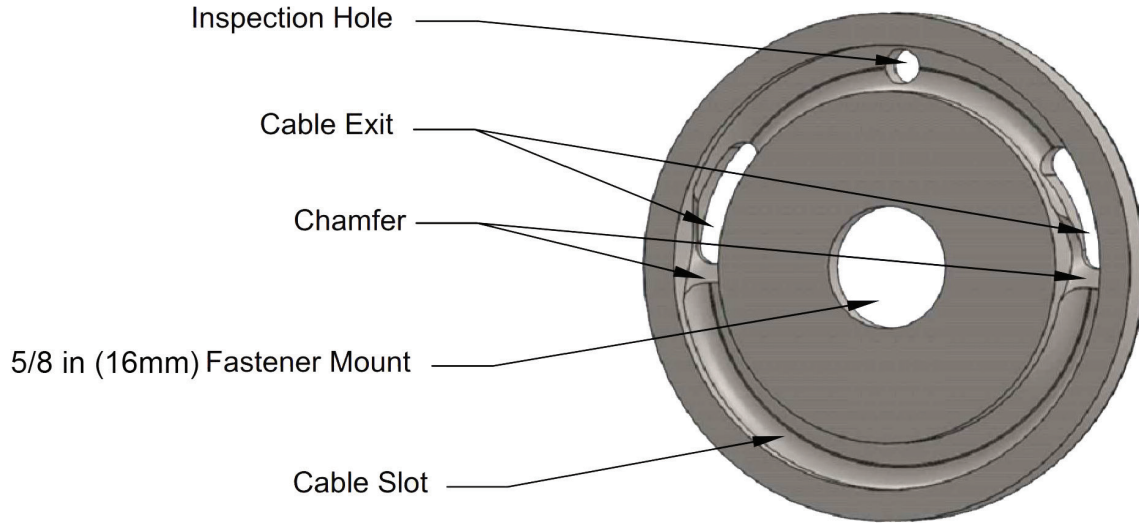

The LPF-5/8 is specifically designed to reduce the prying effect on fasteners. The cable is nested in the groove provided, and exits through two chamfered slots (to prevent damage to the outer fibers of the cable). An inspection hole is provided to ensure that the cable is placed in the correct position within the groove. The LPF has the lowest prying factor yet to be achieved. The cable mount will accept Gold, Orange, and Green cable.

Prying Factor		
Orientation 1		
Angle A	Angle B	Angle C
1.646	0.851	0.429

Prying Factor		
Orientation 2		
Angle D	Angle E	Angle F
0.673	0.818	0.895

Prying Factor		
Orientation 3		
Angle G	Angle H	Angle I
0.500	0.354	0.289

UL Rated Load (lbs-f)	ICC-ES Breaking Strength (lbf)
1,900	1,700

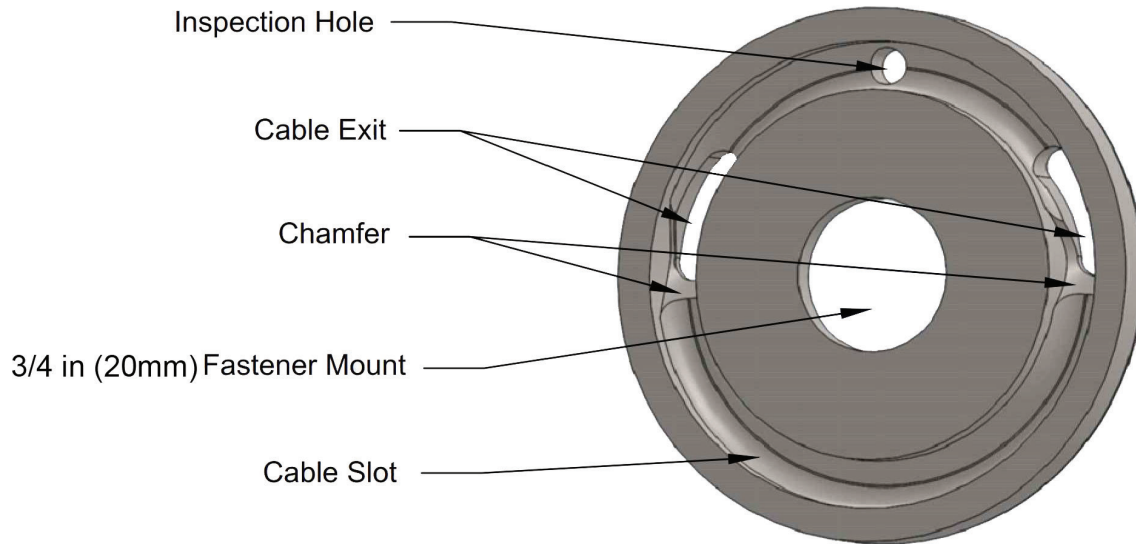

The LPF-3/4 is specifically designed to reduce the prying effect on fasteners. The cable is nested in the groove provided, and exits through two chamfered slots (to prevent damage to the outer fibers of the cable). An inspection hole is provided to ensure that the cable is placed in the correct position within the groove. The LPF has the lowest prying factor yet to be achieved. The cable mount will accept Gold, Orange, and Green cable.

Prying Factor		
Orientation 1		
Angle A	Angle B	Angle C
1.651	0.857	0.434

Prying Factor		
Orientation 2		
Angle D	Angle E	Angle F
0.673	0.818	0.895

Prying Factor		
Orientation 3		
Angle G	Angle H	Angle I
0.500	0.354	0.289

UL Rated Load (lbs-f)	ICC-ES Breaking Strength (lbf)
1,900	1,700

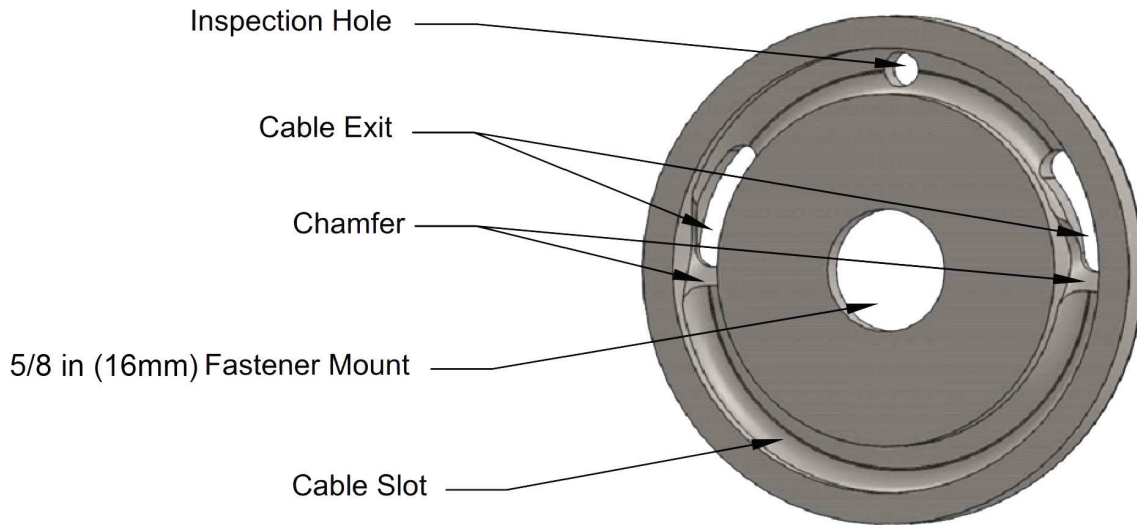

The LPF-7/8 is specifically designed to reduce the prying effect on fasteners. The cable is nested in the groove provided, and exits through two chamfered slots (to prevent damage to the outer fibers of the cable). An inspection hole is provided to ensure that the cable is placed in the correct position within the groove. The LPF has the lowest prying factor yet to be achieved. The cable mount will accept Gold, Orange, and Green cable.

Prying Factor		
Orientation 1		
Angle A	Angle B	Angle C
1.656	0.862	0.439

Prying Factor		
Orientation 2		
Angle D	Angle E	Angle F
0.673	0.818	0.895

Prying Factor		
Orientation 3		
Angle G	Angle H	Angle I
0.500	0.354	0.289

UL Rated Load (lbs-f)
1,900

Cable Kits



Gold (#G03) Cable Kit - 2-Way



The gold 2-way cable kit is available in 5 pre-cut lengths (1', 4', 7', 10', or 13' - an extra 4 feet of cable is added to any pre-cut length). This kit contains 2 lengths of cable with two options of terminals. One option includes a factory-installed stake eye on one end (in 1/4" or 3/8" fastener mounting sizes, either straight or bent on a 45° angle) with 2 oval sleeves. The other option provides 2 cable lengths with no stake eye and 4 oval sleeves, for bar joist loop installation or for use with all sizes of the SAF, SAFR, SAF2, SAF2R, or LPF fittings. Listed for Lateral and Longitudinal installations.

The gold cable kit has a load rating of 418 pounds and is certified to achieve a minimum break strength of 920 pounds.

Orange (#OR4) Cable Kit - 2-Way



The orange 2-way cable kit is available in 5 pre-cut lengths (1', 4', 7', 10', or 13' - an extra 4 feet of cable is added to any pre-cut length). This kit contains 2 lengths of cable with two options of terminals. One option includes a factory-installed stake eye on one end (in 1/4", 3/8", or 1/2" fastener mounting sizes, either straight or bent on a 45° angle) with 2 oval sleeves. The other option provides 2 cable lengths with no stake eye and 4 oval sleeves, for bar joist loop installation or for use with all sizes of the SAF, SAFR, SAF2, SAF2R, or LPF fittings. Listed for Lateral and Longitudinal installations.

The orange cable kit has a load rating of 770 pounds and is certified to achieve a minimum break strength of 1,700 pounds.

Green (#GR6) Cable Kit - 2-Way



The green 2-way cable kit is available in 5 pre-cut lengths (1', 4', 7', 10', or 13' - an extra 4 feet of cable is added to any pre-cut length). This kit contains 2 lengths of cable with two options of terminals. One option includes a factory-installed stake eye on one end (in 3/8" or 1/2" fastener mounting sizes, either straight or bent on a 45° angle) with 2 oval sleeves. The other option provides 2 cable lengths with no stake eye and 4 oval sleeves, for bar joist loop installation or for use with all sizes of the SAF, SAF2, or LPF fittings. Listed for Lateral and Longitudinal installations.

The green cable kit has a load rating of 1,360 pounds and is certified to achieve a minimum break strength of 3,000 pounds. The green cable kit's load rating and certified minimum breaking strength differs from the green cable.

Black (#BL8) Cable Kit - 2-Way



The black 2-way cable kit is available in 5 pre-cut lengths (1', 4', 7', 10', or 13' - an extra 4 feet of cable is added to any pre-cut length). This kit contains 2 lengths of cable with two options of terminals. One option includes a factory-installed stake eye on one end (in 5/8" fastener mounting size, either straight or bent on a 45° angle) with 2 oval sleeves. The other option provides 2 cable lengths with no stake eye and 4 oval sleeves for bar joist loop installation. Listed for Lateral and Longitudinal installations.

The black cable kit has a load rating of 3,180 pounds and is certified to achieve a minimum break strength of 7,000 pounds.

Gold (#G03) Cable Kit - 4-Way



The gold 4-way cable kit is available in 5 pre-cut lengths (1', 4', 7', 10', or 13' - an extra 4 feet of cable is added to any pre-cut length). This kit contains 4 lengths of cable with two options of terminals. One option includes a factory-installed stake eye on one end (in 1/4" or 3/8" fastener mounting sizes, either straight or bent on a 45° angle) with 4 oval sleeves. The other option provides 4 cable lengths with no stake eye and 8 oval sleeves, for bar joist loop installation or for use with all sizes of the SAF, SAFR, SAF2, SAF2R, or LPF fittings. Listed for 4-way installations.

The gold cable kit has a load rating of 418 pounds and is certified to achieve a minimum break strength of 920 pounds.

Orange (#OR4) Cable Kit - 4-Way



The orange 4-way cable kit is available in 5 pre-cut lengths (1', 4', 7', 10', or 13' - an extra 4 feet of cable is added to any pre-cut length). This kit contains 4 lengths of cable with two options of terminals. One option includes a factory-installed stake eye on one end (in 1/4", 3/8", or 1/2" fastener mounting sizes, either straight or bent on a 45° angle) with 4 oval sleeves. The other option provides 4 cable lengths with no stake eye and 8 oval sleeves, for bar joist loop installation or for use with all sizes of the SAF, SAFR, SAF2, SAF2R, or LPF fittings. Listed for 4-way installations.

The orange cable kit has a load rating of 770 pounds and is certified to achieve a minimum break strength of 1,700 pounds.

Green (#GR6) Cable Kit - 4-Way



The green 4-way cable kit is available in 5 pre-cut lengths (1', 4', 7', 10', or 13' - an extra 4 feet of cable is added to any pre-cut length). This kit contains 4 lengths of cable with two options of terminals. One option includes a factory-installed stake eye on one end (in 3/8" or 1/2" fastener mounting sizes, either straight or bent on a 45° angle) with 4 oval sleeves. The other option provides 4 cable lengths with no stake eye and 8 oval sleeves, for bar joist loop installation or for use with all sizes of the SAF, SAF2, or LPF fittings. Listed for 4-way installations.

The green cable kit has a load rating of 1,360 pounds and is certified to achieve a minimum break strength of 3,000 pounds. The green cable kit's load rating and certified minimum breaking strength differs from the green cable.

Black (#BL8) Cable Kit - 4-Way



The black 4-way cable kit is available in 5 pre-cut lengths (1', 4', 7', 10', or 13' - an extra 4 feet of cable is added to any pre-cut length). This kit contains 4 lengths of cable with two options of terminals. One option includes a factory-installed stake eye on one end (in 5/8" fastener mounting size, either straight or bent on a 45° angle) with 4 oval sleeves. The other option provides 4 cable lengths with no stake eye and 8 oval sleeves for bar joist loop installation. Listed for 4-way installations.

The black cable kit has a load rating of 3,180 pounds and is certified to achieve a minimum break strength of 7,000 pounds.

Installation Instructions



Lateral Brace

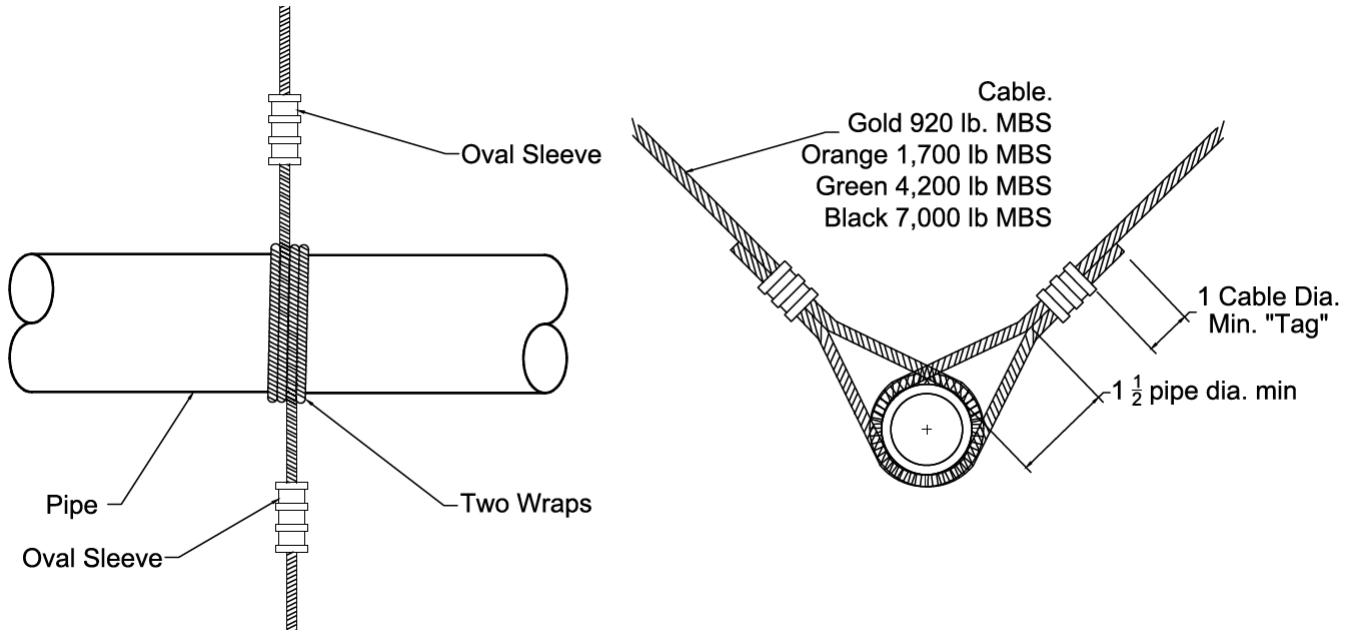

1. Slide oval sleeve onto end of cable. Slide sleeve up cable to allow working room.
2. Wrap cable around pipe twice. Form a simple knot on the second wrap to hold the cable in place.
3. Slide loose end of the cable into sleeve and pull cable to remove slack.
4. Crimp sleeve per Figure 1 below.
5. Repeat in opposite direction.

Figure 1

Size	Cable Color	Number of Crimps	Certified Minimum Break Strength (lbs)	Load Rating (lbs)
#GO3	Gold	2	920	418
#OR4	Orange	2	1,700	770
#GR6	Green	3	4,200	1,900
#BL8	Black	3	7,000	3,180

INSTRUCTIONS

Longitudinal Brace

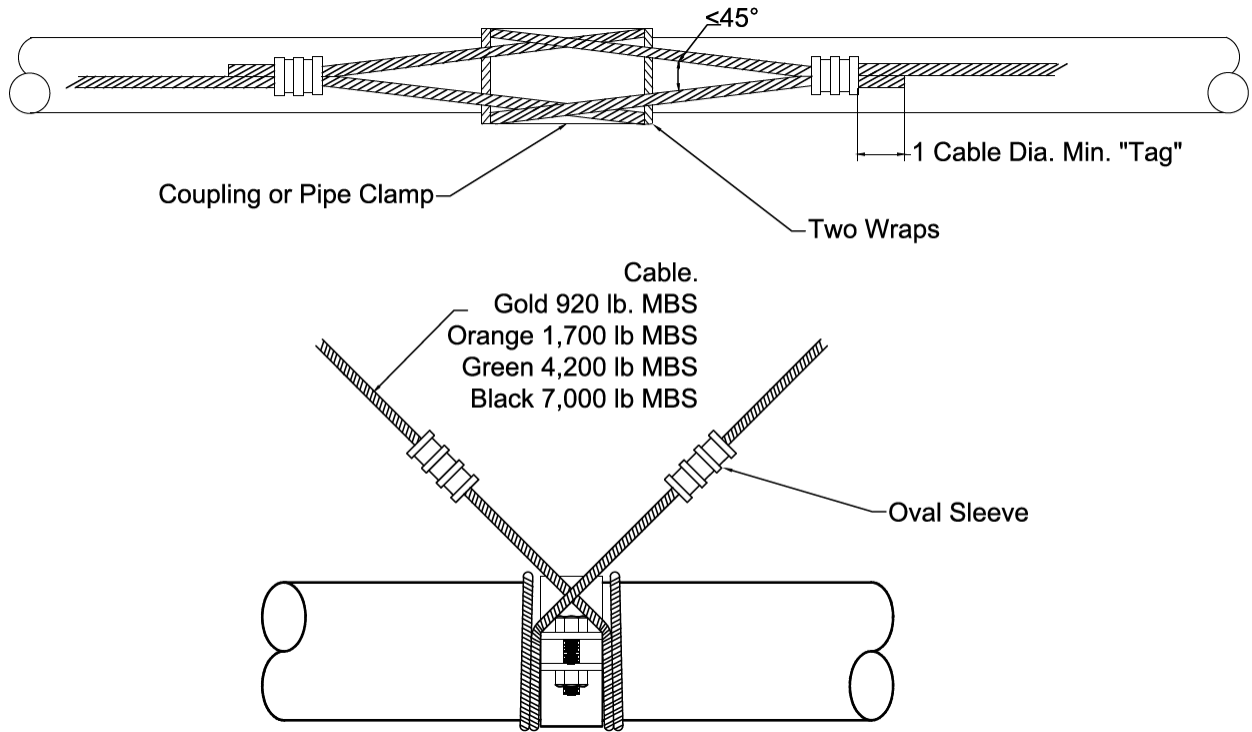

1. Slide oval sleeve onto end of cable. Slide sleeve up cable to allow working room.
2. Wrap cable around pipe twice. Form a simple knot on the second wrap to hold the cable in place. Be sure the wrap is on the far side of a pipe clamp or grooved coupling, and not on it.
3. Slide loose end of the cable into sleeve and pull cable to remove slack.
4. Crimp sleeve per Figure 1 below.
5. Repeat in opposite direction.

Figure 1

Size	Cable Color	Number of Crimps	Certified Minimum Break Strength (lbs)	Load Rating (lbs)
#GO3	Gold	2	920	418
#OR4	Orange	2	1,700	770
#GR6	Green	3	4,200	1,900
#BL8	Black	3	7,000	3,180



4-Way Brace

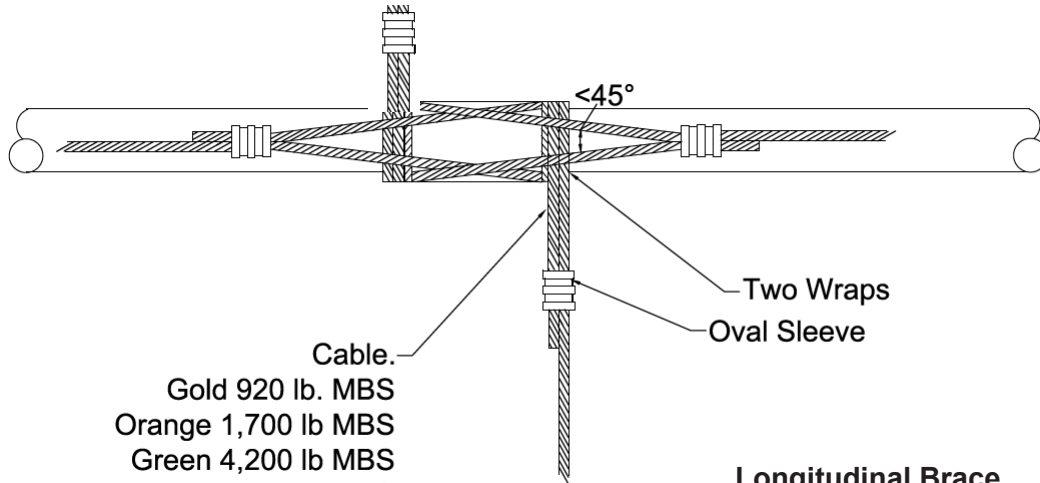

Lateral Brace

1. Slide oval sleeve onto end of cable. Slide sleeve up cable to allow working room.
2. Wrap cable around pipe twice. Form a simple knot on the second wrap to hold the cable in place.
3. Slide loose end of the cable into sleeve and pull cable to remove slack.
4. Crimp sleeve per Figure 1 below.
5. Repeat in opposite direction.

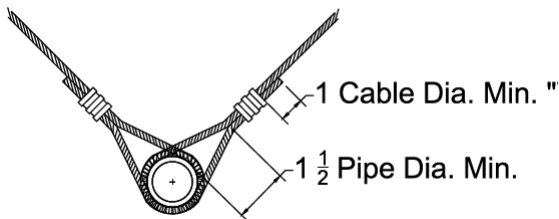

Longitudinal Brace

1. Slide oval sleeve onto end of cable. Slide sleeve up cable to allow working room.
2. Wrap cable around pipe twice. Form a simple knot on the second wrap to hold the cable in place. Be sure the wrap is on the far side of a pipe clamp or grooved coupling, and not on it.
3. Slide loose end of the cable into sleeve and pull cable to remove slack.
4. Crimp sleeve per Figure 1 below.
5. Repeat in opposite direction.

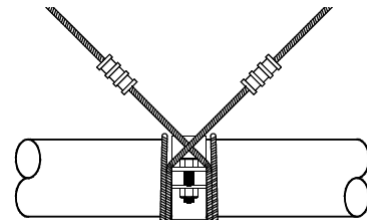

Figure 1

Size	Cable Color	Number of Crimps	Certified Minimum Break Strength (lbs)	Load Rating (lbs)
#GO3	Gold	2	920	418
#OR4	Orange	2	1,700	770
#GR6	Green	3	4,200	1,900
#BL8	Black	3	7,000	3,180

Splicing Instructions



1. Slide one end of the first cable through both sleeves on the same side of the oval sleeve.
2. Slide one end of the second cable through both sleeves on the opposite side of the oval sleeves
3. 1" min space and crimp the two oval sleeves as per Table 1.

Table 1

Tools and Sleeves			
Cable Color	Sleeve Size	Tool	Crimps
Gold	3/32"	#0-3-SBHS	2
		#3-346-SB	2
		SL-7NDK-SB3	1
Orange	1/8" *	#0-3-SBHS	4
		#3-346-SB*	3
		SL-7NDK-SB3	1
Green	3/16"	0-3/16SC	3
		#3-346-SB	3
		SL-7NDK-SB6	2
Black	1/4"	0-1/4	3
		SL-7NDK-SB8	3

* Thin wall sleeve using 3/32" cavity



Load: Perpendicular to Structural Member

Angles: A (30°), B (45°), and C (60°)

Material: Through-bolts in Sawn Lumber or Glue-Laminated Timbers

Table: 18.5.12.2 (L)

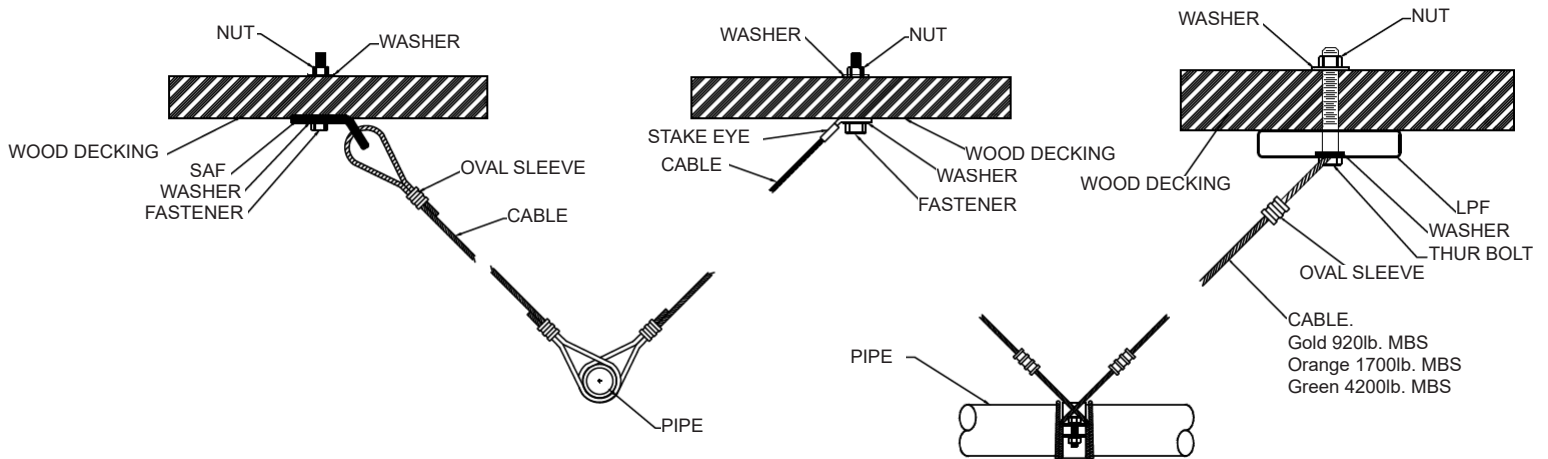

Bolt Length	1/2" Bolt Diameter			5/8" Bolt Diameter			3/4" Bolt Diameter		
	30° - 44°	45° - 59°	60° - 90°	30° - 44°	45° - 59°	60° - 90°	30° - 44°	45° - 59°	60° - 90°
1-1/2"	115 lbs.	165 lbs.	200 lbs.	135 lbs.	190 lbs.	235 lbs.	155 lbs.	220 lbs.	270 lbs.
2-1/2"	140 lbs.	200 lbs.	240 lbs.	160 lbs.	225 lbs.	280 lbs.	180 lbs.	255 lbs.	310 lbs.
3-1/2"	175 lbs.	250 lbs.	305 lbs.	200 lbs.	285 lbs.	345 lbs.	220 lbs.	310 lbs.	380 lbs.
5-1/2"	N/A	N/A	N/A	280 lbs.	395 lbs.	485 lbs.	310 lbs.	440 lbs.	535 lbs.

Above listed values based on wood with a specific gravity of 0.35. Values for other woods can be obtained by multiplying above values by factors listed in Figure 1.

Figure 1

Specific Gravity of Wood	Multiplier
0.36 - 0.49	1.17
0.50 - 0.65	1.25
0.66 - 0.73	1.50



INSTRUCTIONS

Load: Perpendicular to Structural Member

Angles: A (30°), B (45°), and C (60°)

Material: Lag Screw and Lag Bolts in Wood

Table: 18.5.12.2 (M)

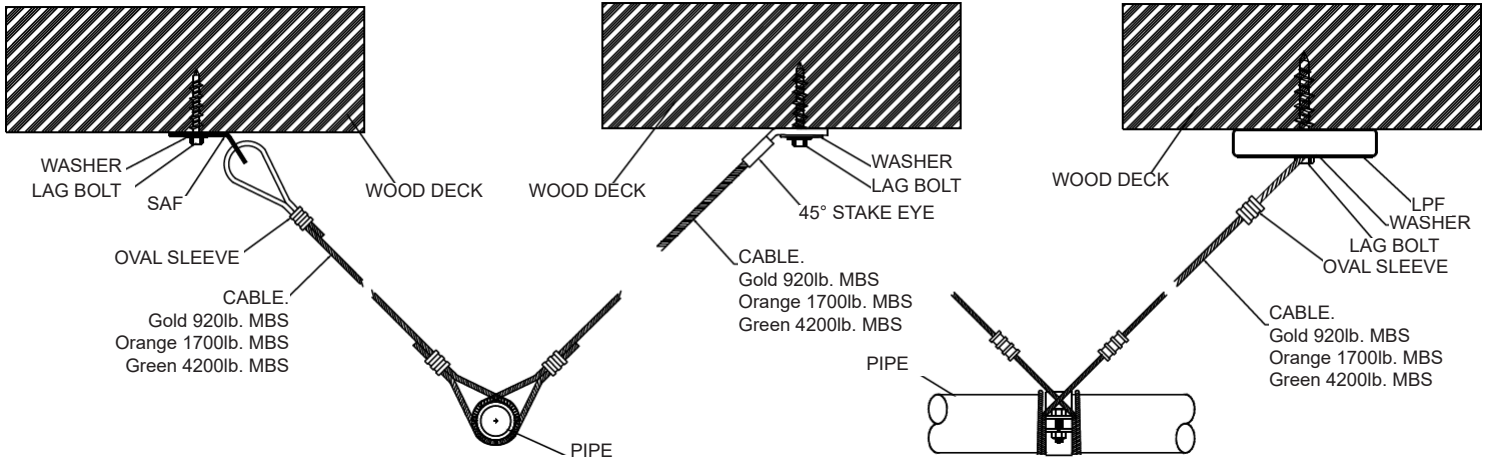

Lag Length	3/8" Lag Diameter			1/2" Lag Diameter			5/8" Lag Diameter		
	30° - 44°	45° - 59°	60° - 90°	30° - 44°	45° - 59°	60° - 90°	30° - 44°	45° - 59°	60° - 90°
3-1/2"	165 lbs.	190 lbs.	200 lbs.						
4-1/2"	180 lbs.	200 lbs.	200 lbs.	300 lbs.	355 lbs.	380 lbs.			
5-1/2"	190 lbs.	200 lbs.	200 lbs.	320 lbs.	370 lbs.	380 lbs.	435 lbs.	525 lbs.	555 lbs.
6-1/2"	195 lbs.	205 lbs.	200 lbs.	340 lbs.	375 lbs.	380 lbs.	465 lbs.	540 lbs.	555 lbs.

Above listed values based on wood with a specific gravity of 0.35. Values for other woods can be obtained by multiplying above values by factors listed in Figure 1.

Figure 1

Specific Gravity of Wood	Multiplier
0.36 - 0.49	1.17
0.50 - 0.65	1.25
0.66 - 0.73	1.50



Load: Perpendicular to Structural Member

Angles: A (30°), B (45°), and C (60°)

Material: Wedge anchors in 3,000 PSI (207 bar) Lightweight Cracked Concrete on Metal Decking

Table: 18.5.12.2 (A)

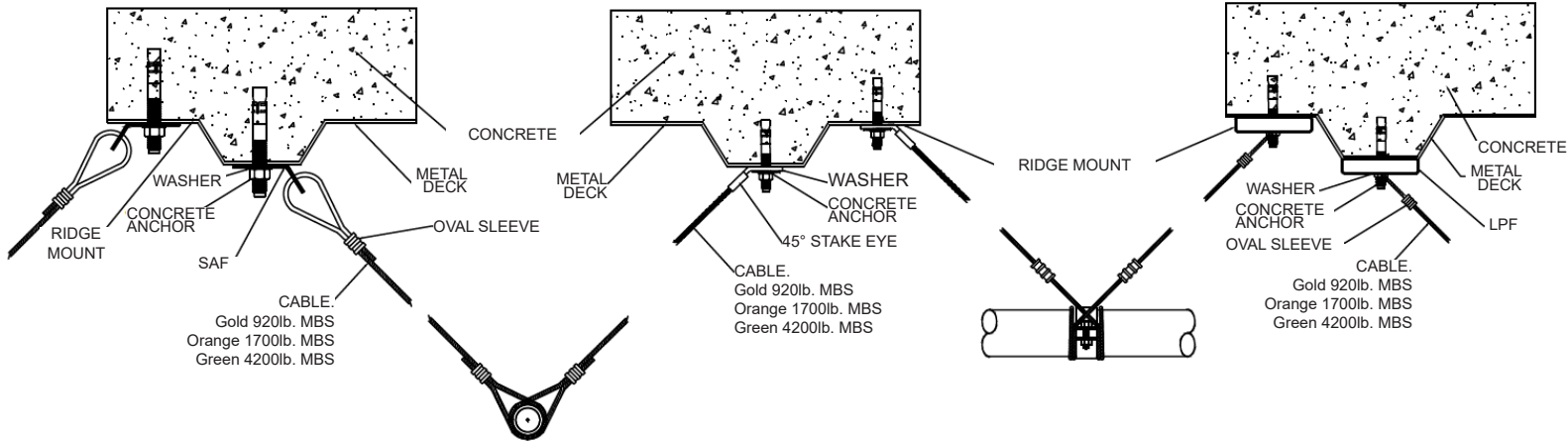

Maximum Load for Wedge Anchors in 3,000 psi (207 bar) Lightweight Cracked Concrete on Metal Deck

Fastener Diameter	Fastener Min. Nom. Embedment	Min. Slab Thickness	Max. Flute Center Offset	LPF			SAF (All)			Stake Eye		
				30°-44°	45°-59°	60°-90°	30°-44°	45°-59°	60°-90°	30°-44°	45°-59°	60°-90°
3/8"	2.375	6.25	1	123 lbs.	183 lbs.	233 lbs.	79 lbs.	133 lbs.	193 lbs.	79 lbs.	133 lbs.	193 lbs.
1/2"	3.750	6.25	1	147 lbs.	231 lbs.	310 lbs.	86 lbs.	160 lbs.	247 lbs.	86 lbs.	160 lbs.	247 lbs.
5/8"	3.875	6.25	1	188 lbs.	292 lbs.	387 lbs.	113 lbs.	204 lbs.	311 lbs.	N/A	N/A	N/A
3/4"	4.500	6.25	1	255 lbs.	380 lbs.	486 lbs.	165 lbs.	275 lbs.	402 lbs.	N/A	N/A	N/A



INSTRUCTIONS

Load: Perpendicular to Structural Member

Angles: A (30°), B (45°), and C (60°)

Material: Wedge Anchors in 3,000 PSI (207 bars) Normal Weight Cracked Concrete

Table: 18.5.12.2 (C)

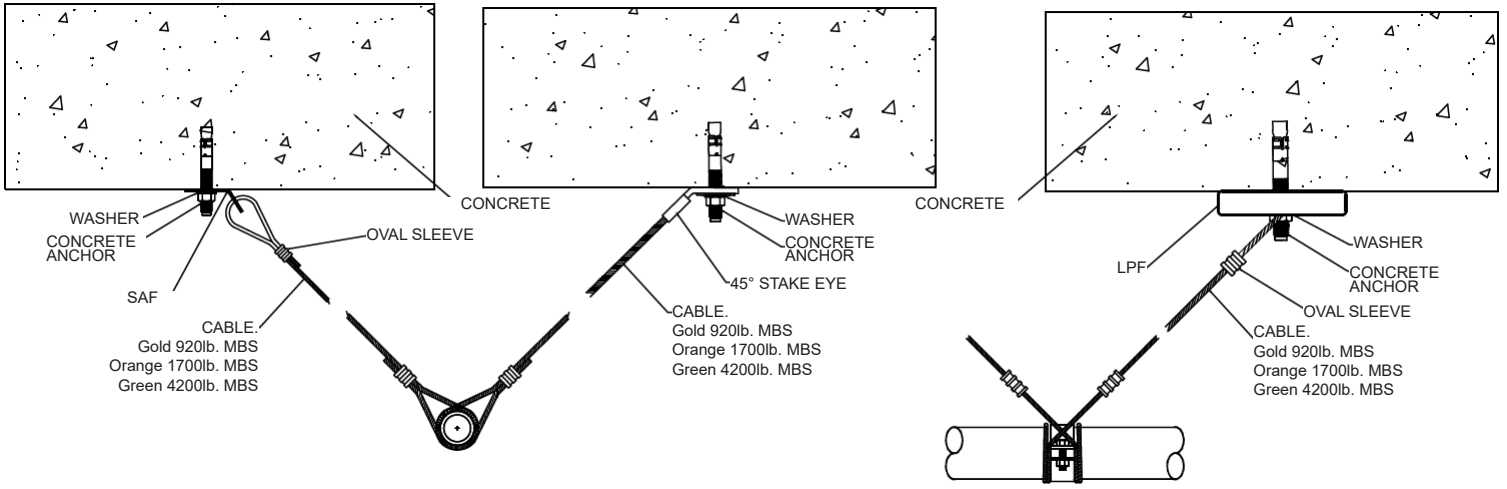

Maximum Load for Wedge Anchors in 3,000 psi (207 bar) Normal-Weight Cracked Concrete

Fastener Diameter	Fastener Min. Nom. Embedment	Min. Slab Thickness	Min. Edge Distance (in.)	LPF			SAF (All)			Stake Eye		
				30°-44°	45°-59°	60°-90°	30°-44°	45°-59°	60°-90°	30°-44°	45°-59°	60°-90°
3/8"	2.375	5	4	189 lbs.	274 lbs.	342 lbs.	125 lbs.	203 lbs.	288 lbs.	125 lbs.	203 lbs.	288 lbs.
1/2"	3.750	6	6	272 lbs.	423 lbs.	563 lbs.	162 lbs.	295 lbs.	451 lbs.	162 lbs.	295 lbs.	451 lbs.
5/8"	3.875	6	6	407 lbs.	623 lbs.	814 lbs.	252 lbs.	441 lbs.	662 lbs.	N/A	N/A	N/A
3/4"	4.500	7	8	613 lbs.	940 lbs.	1,232 lbs.	378 lbs.	665 lbs.	999 lbs.	N/A	N/A	N/A



Load: Perpendicular to Structural Member

Angles: A (30°), B (45°), and C (60°)

Material: Wood Form Inserts in 3,000 PSI (207 bar) Normal Weight Cracked Concrete

Table: 18.5.12.2 (H)

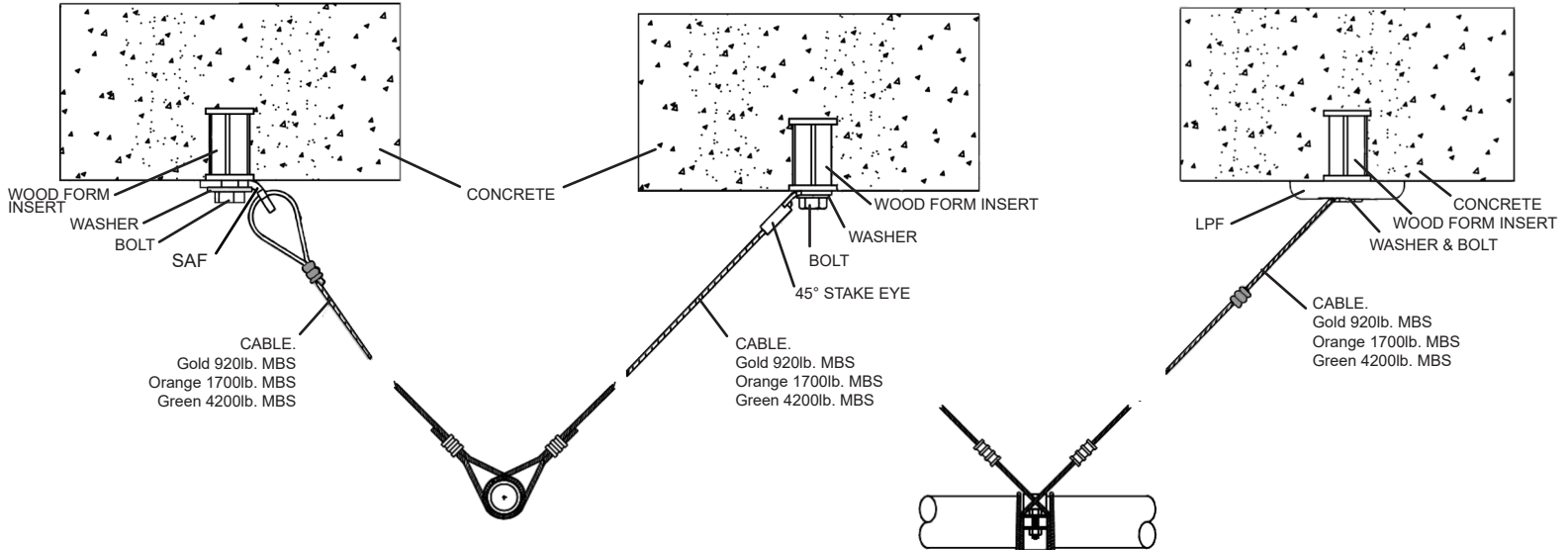

Maximum Load for Wood Form Inserts in 3,000 psi (207 bar) Normal-Weight Cracked Concrete

Fastener Diameter	Fastener Min. Nom. Embedment	Min. Slab Thickness	Min. Edge Distance (in.)	LPF			SAF (All)			Stake Eye		
				30°-44°	45°-59°	60°-90°	30°-44°	45°-59°	60°-90°	30°-44°	45°-59°	60°-90°
3/8"	1.100	4	6	248 lbs.	342 lbs.	411 lbs.	170 lbs.	264 lbs.	357 lbs.	170 lbs.	264 lbs.	357 lbs.
1/2"	1.690	4	6	297 lbs.	443 lbs.	565 lbs.	192 lbs.	321 lbs.	468 lbs.	192 lbs.	321 lbs.	468 lbs.
5/8"	1.750	4	8	297 lbs.	443 lbs.	565 lbs.	192 lbs.	321 lbs.	468 lbs.	N/A	N/A	N/A
3/4"	1.750	4	8	297 lbs.	443 lbs.	565 lbs.	192 lbs.	321 lbs.	468 lbs.	N/A	N/A	N/A



INSTRUCTIONS

Load: Perpendicular to Structural Member

Angles: A (30°), B (45°), and C (60°)

Material: Wedge anchors in 3,000 PSI (207 bar) Light Weight Cracked Concrete

Table: 18.5.12.2 (B)

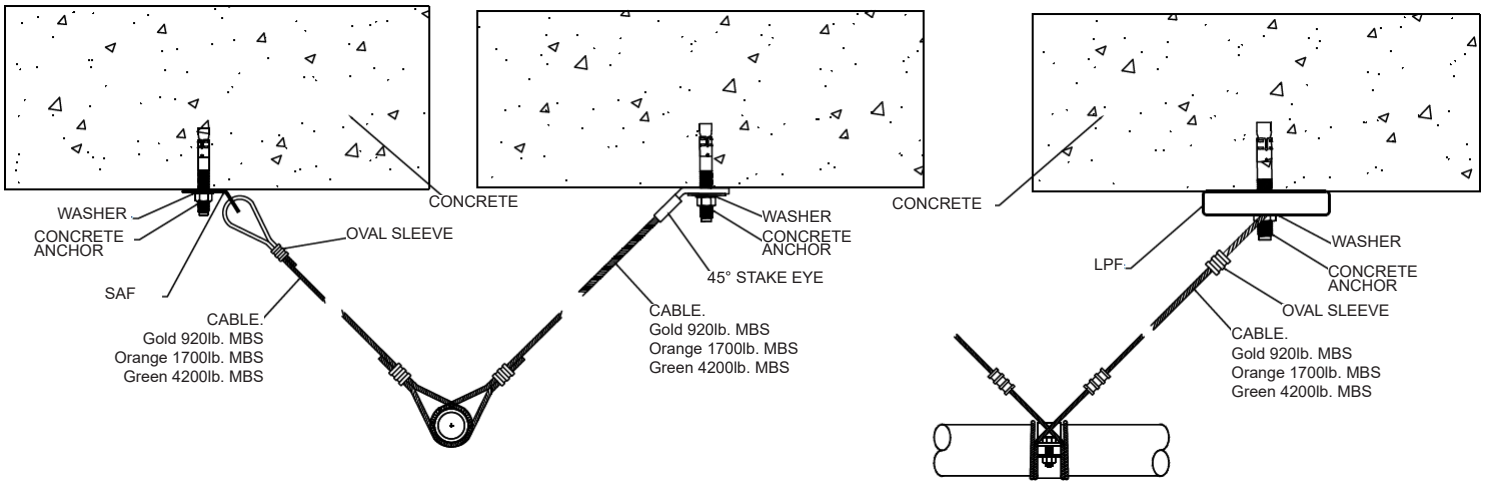

Maximum Load for Wedge Anchors in 3,000 psi (207 bar) Lightweight Cracked Concrete

Fastener Diameter	Fastener Min. Nom. Embedment	Min. Slab Thickness	Min. Edge Distance (in.)	LPF			SAF (All)			Stake Eye		
				30°-44°	45°-59°	60°-90°	30°-44°	45°-59°	60°-90°	30°-44°	45°-59°	60°-90°
3/8"	2.375	5	4	142 lbs.	216 lbs.	280 lbs.	89 lbs.	154 lbs.	229 lbs.	89 lbs.	154 lbs.	229 lbs.
1/2"	3.750	6	6	200 lbs.	314 lbs.	419 lbs.	119 lbs.	218 lbs.	335 lbs.	119 lbs.	218 lbs.	335 lbs.
5/8"	3.875	6	6	259 lbs.	394 lbs.	512 lbs.	163 lbs.	281 lbs.	418 lbs.	N/A	N/A	N/A
3/4"	4.500	7	8	356 lbs.	552 lbs.	731 lbs.	214 lbs.	386 lbs.	588 lbs.	N/A	N/A	N/A



Load: Perpendicular to Structural Member

Angles: A (30°), B (45°), and C (60°)

Material: Wedge Anchors in 4,000 PSI (276 bar) Normal Weight Cracked Concrete

Table: 18.5.12.2 (D)

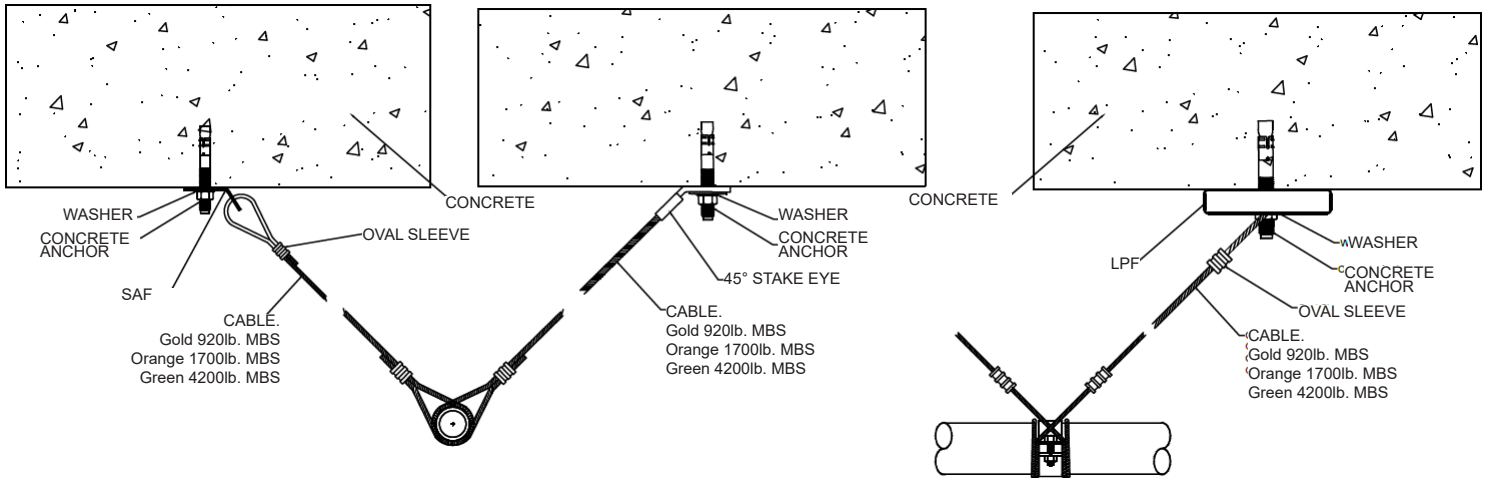

Maximum Load for Wedge Anchors in 4,000 psi (267 bar) Normal-Weight Cracked Concrete

Fastener Diameter	Fastener Min. Nom. Embedment	Min. Slab Thickness	Min. Edge Distance (in.)	LPF			SAF (All)			Stake Eye		
				30°-44°	45°-59°	60°-90°	30°-44°	45°-59°	60°-90°	30°-44°	45°-59°	60°-90°
3/8"	2.375	5	4	206 lbs.	293 lbs.	360 lbs.	138 lbs.	221 lbs.	307 lbs.	138 lbs.	221 lbs.	307 lbs.
1/2"	3.750	6	6	304 lbs.	466 lbs.	610 lbs.	188 lbs.	330 lbs.	495 lbs.	188 lbs.	330 lbs.	495 lbs.
5/8"	3.875	6	6	469 lbs.	716 lbs.	935 lbs.	291 lbs.	508 lbs.	761 lbs.	N/A	N/A	N/A
3/4"	4.500	7	8	657 lbs.	997 lbs.	1,293 lbs.	414 lbs.	711 lbs.	1,057 lbs.	N/A	N/A	N/A



INSTRUCTIONS

Load: Perpendicular to Structural Member

Angles: A (30°), B (45°), and C (60°)

Material: Wedge Anchors in 6,000 PSI (414 bar) Normal Weight Cracked Concrete

Table: 18.5.12.2 (E)

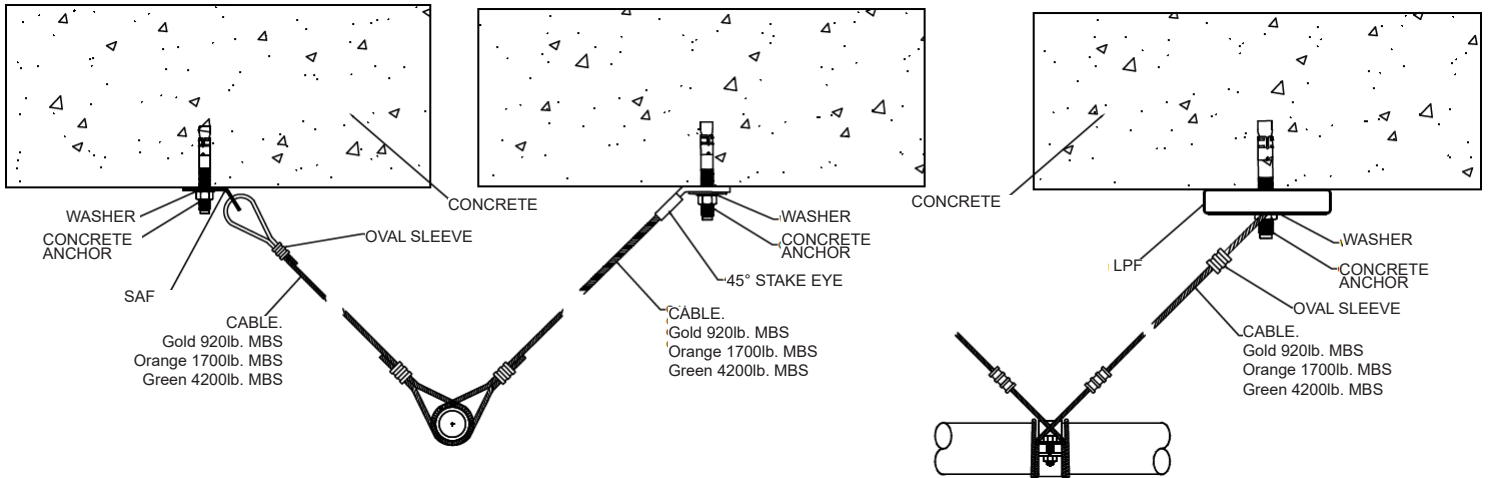

Maximum Load for Wedge Anchors in 6,000 psi (414 bar) Normal-Weight Cracked Concrete

Fastener Diameter	Fastener Min. Nom. Embedment	Min. Slab Thickness	Min. Edge Distance (in.)	LPF			SAF (All)			Stake Eye		
				30°-44°	45°-59°	60°-90°	30°-44°	45°-59°	60°-90°	30°-44°	45°-59°	60°-90°
3/8"	2.375	5	4	225 lbs.	313 lbs.	379 lbs.	153 lbs.	240 lbs.	327 lbs.	153 lbs.	240 lbs.	327 lbs.
1/2"	3.750	6	6	354 lbs.	529 lbs.	676 lbs.	228 lbs.	382 lbs.	559 lbs.	228 lbs.	382 lbs.	559 lbs.
5/8"	3.875	6	6	546 lbs.	812 lbs.	1,036 lbs.	353 lbs.	589 lbs.	859 lbs.	N/A	N/A	N/A
3/4"	4.500	7	8	763 lbs.	1,127 lbs.	1,429 lbs.	496 lbs.	822 lbs.	1,190 lbs.	N/A	N/A	N/A



Load: Perpendicular to Structural Member

Angles: A (30°), B (45°), and C (60°)

Material: Connections to Steel Using Unfinished Steel Bolts

Table: 18.5.12.2 (K)

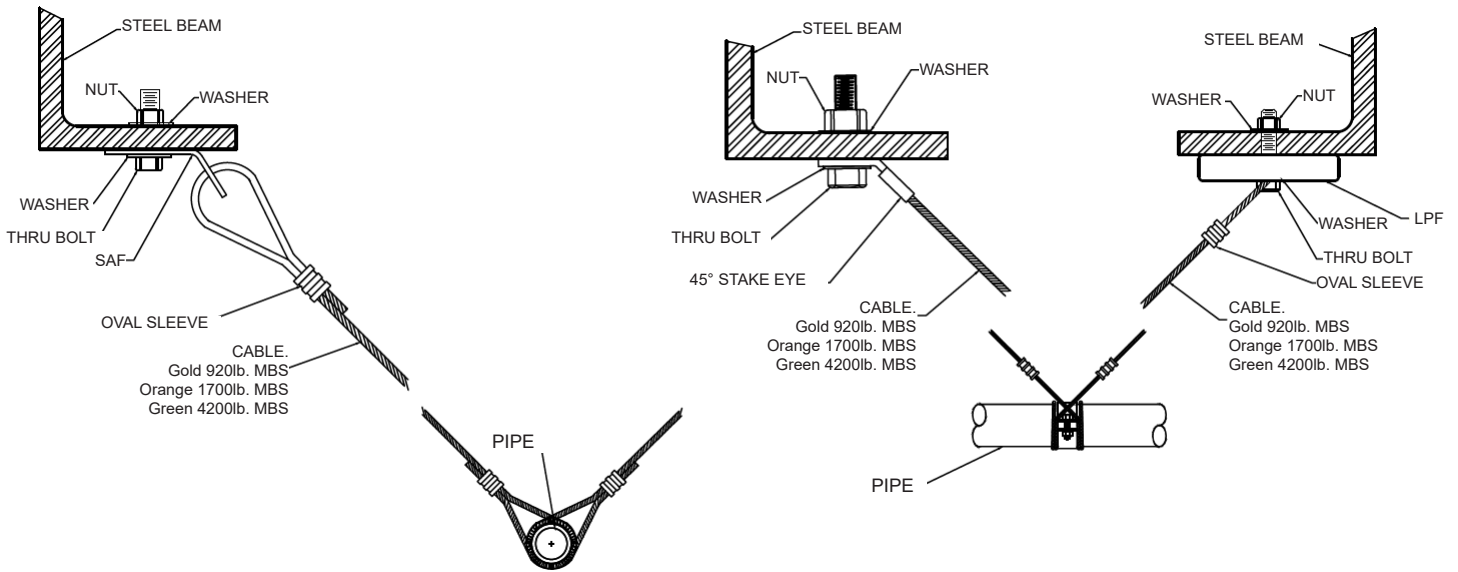

Diameter	30° - 44°	45° - 59°	60° - 90°
1/4"	400 lbs.	500 lbs.	600 lbs.
3/8"	900 lbs.	1,200 lbs.	1,400 lbs.
1/2"	1,600 lbs.	2,050 lbs.	2,550 lbs.
5/8"	2,500 lbs.	3,300 lbs.	3,950 lbs.



INSTRUCTIONS

Load: Perpendicular to Structural Member

Angles: D (30°), E (45°), and F (60°)

Material: Through-Bolts in Sawn Lumber or Glue-Laminated Timber

Table: 18.5.12.2 (L)

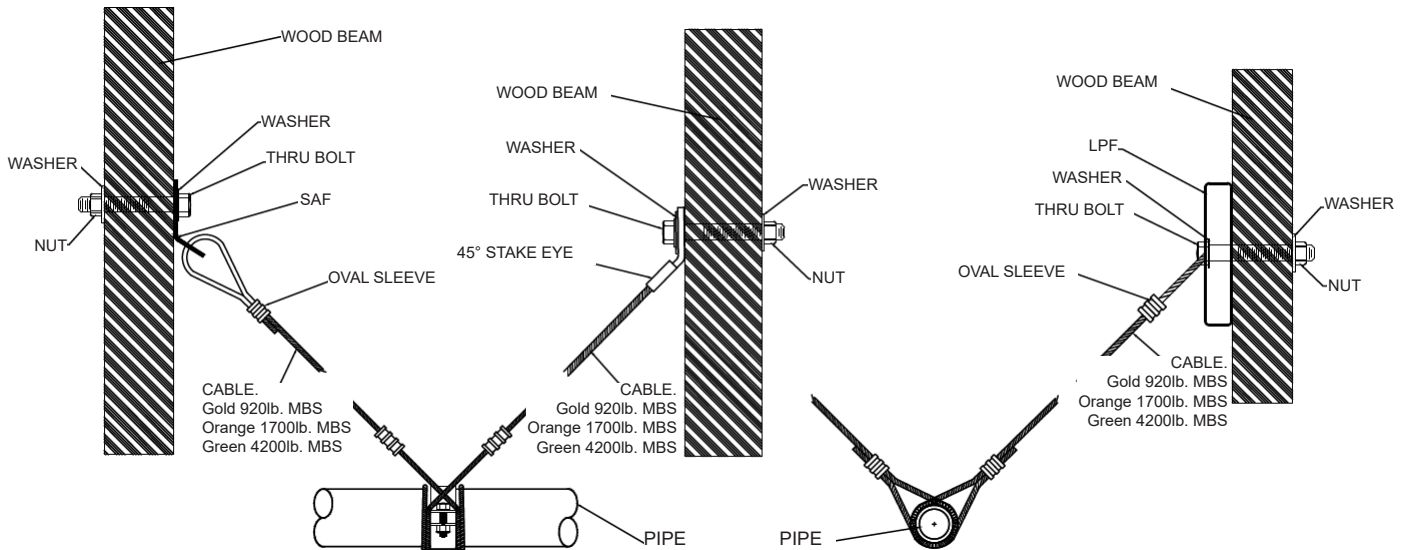

Bolt Length	1/2" Bolt Diameter			5/8" Bolt Diameter			3/4" Bolt Diameter		
	30° - 44°	45° - 59°	60° - 90°	30° - 44°	45° - 59°	60° - 90°	30° - 44°	45° - 59°	60° - 90°
1-1/2"	135 lbs.	230 lbs.	395 lbs.	155 lbs.	270 lbs.	460 lbs.	180 lbs.	310 lbs.	530 lbs.
2-1/2"	160 lbs.	280 lbs.	480 lbs.	185 lbs.	320 lbs.	550 lbs.	205 lbs.	360 lbs.	615 lbs.
3-1/2"	200 lbs.	350 lbs.	600 lbs.	230 lbs.	400 lbs.	685 lbs.	255 lbs.	440 lbs.	755 lbs.
5-1/2"	N/A	N/A	N/A	325 lbs.	560 lbs.	960 lbs.	360 lbs.	620 lbs.	1,065 lbs.

Above listed values based on wood with a specific gravity of 0.35. Values for other woods can be obtained by multiplying above values by factors listed in Figure 1.

Figure 1

Specific Gravity of Wood	Multiplier
0.36 - 0.49	1.17
0.50 - 0.65	1.25
0.66 - 0.73	1.50



Load: Perpendicular to Structural Member

Angles: D (30°), E (45°), and F (60°)

Material: Lag Screw and Lag Bolts in wood

Table: 18.5.12.2 (M)

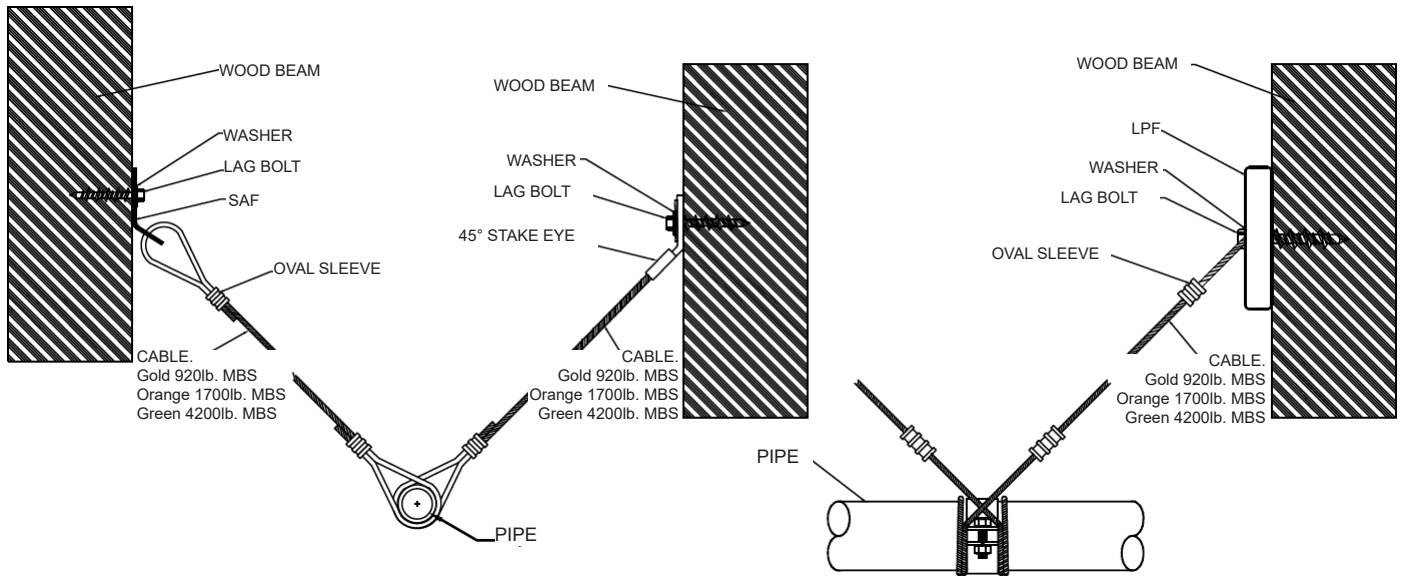

Lag Length	3/8" Lag Diameter			1/2" Lag Diameter			5/8" Lag Diameter		
	30° - 44°	45° - 59°	60° - 90°	30° - 44°	45° - 59°	60° - 90°	30° - 44°	45° - 59°	60° - 90°
3-1/2"	170 lbs.	220 lbs.	310 lbs.						
4-1/2"	175 lbs.	235 lbs.	350 lbs.	315 lbs.	400 lbs.	550 lbs.			
5-1/2"	175 lbs.	245 lbs.	380 lbs.	320 lbs.	420 lbs.	610 lbs.	425 lbs.	550 lbs.	775 lbs.
6-1/2"	175 lbs.	250 lbs.	400 lbs.	325 lbs.	435 lbs.	650 lbs.	430 lbs.	570 lbs.	840 lbs.

Above listed values based on wood with a specific gravity of 0.35. Values for other woods can be obtained by multiplying above values by factors listed in Figure 1.

Figure 1

Specific Gravity of Wood	Multiplier
0.36 - 0.49	1.17
0.50 - 0.65	1.25
0.66 - 0.73	1.50



INSTRUCTIONS

Load: Perpendicular to Structural Member

Angles: D (30°), E (45°), and F (60°)

Material: Wedge Anchors in 3,000 PSI (207 bars) Normal Weight Cracked Concrete

Table: 18.5.12.2 (C)

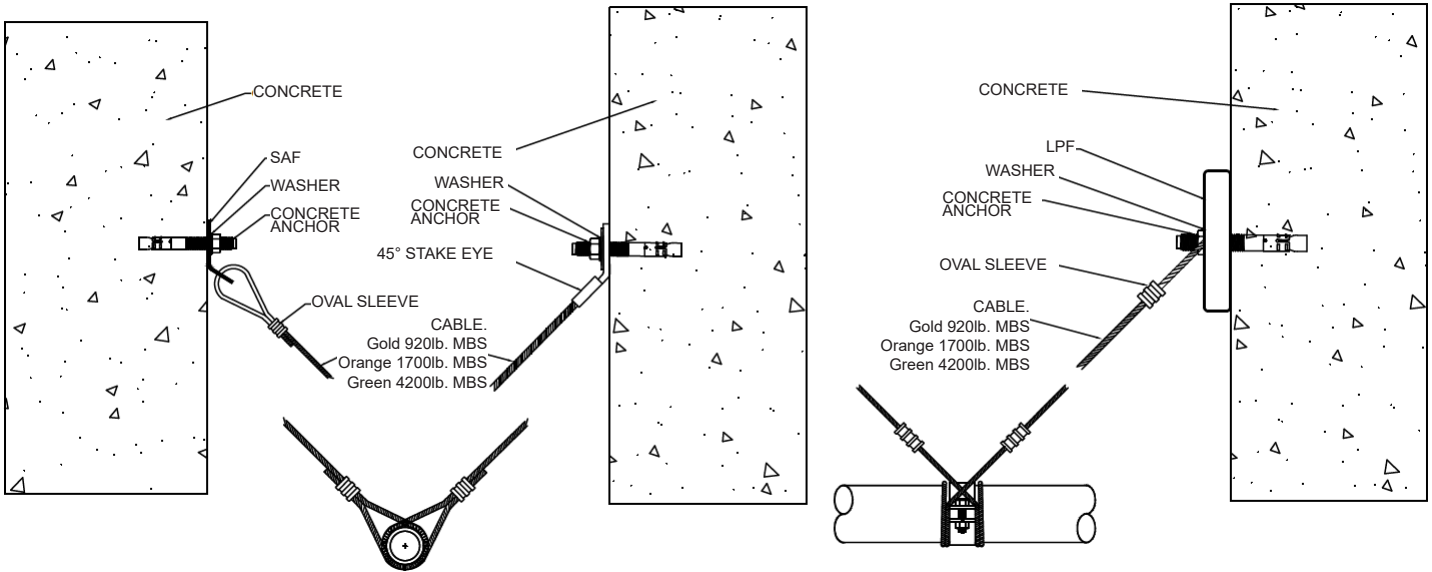

Maximum Load for Wedge Anchors in 3,000 psi (207 bar) Normal-Weight Cracked Concrete

Fastener Diameter	Fastener Min. Nom. Embedment	Min. Slab Thickness	Min. Edge Distance (in.)	LPF			SAF (All)			Stake Eye		
				30°-44°	45°-59°	60°-90°	30°-44°	45°-59°	60°-90°	30°-44°	45°-59°	60°-90°
3/8"	2.375	5	4	197 lbs.	274 lbs.	340 lbs.	167 lbs.	203 lbs.	219 lbs.	167 lbs.	203 lbs.	219 lbs.
1/2"	3.750	6	6	326 lbs.	423 lbs.	490 lbs.	263 lbs.	295 lbs.	285 lbs.	263 lbs.	295 lbs.	285 lbs.
5/8"	3.875	6	6	472 lbs.	623 lbs.	733 lbs.	386 lbs.	441 lbs.	442 lbs.	N/A	N/A	N/A
3/4"	4.500	7	8	715 lbs.	940 lbs.	1,104 lbs.	583 lbs.	665 lbs.	662 lbs.	N/A	N/A	N/A



Load: Perpendicular to Structural Member

Angles: D (30°), E (45°), and F (60°)

Material: Wood Form Insert in 3,000 PSI (207 bar) Normal Weight Cracked Concrete

Table: 18.5.12.2 (H)

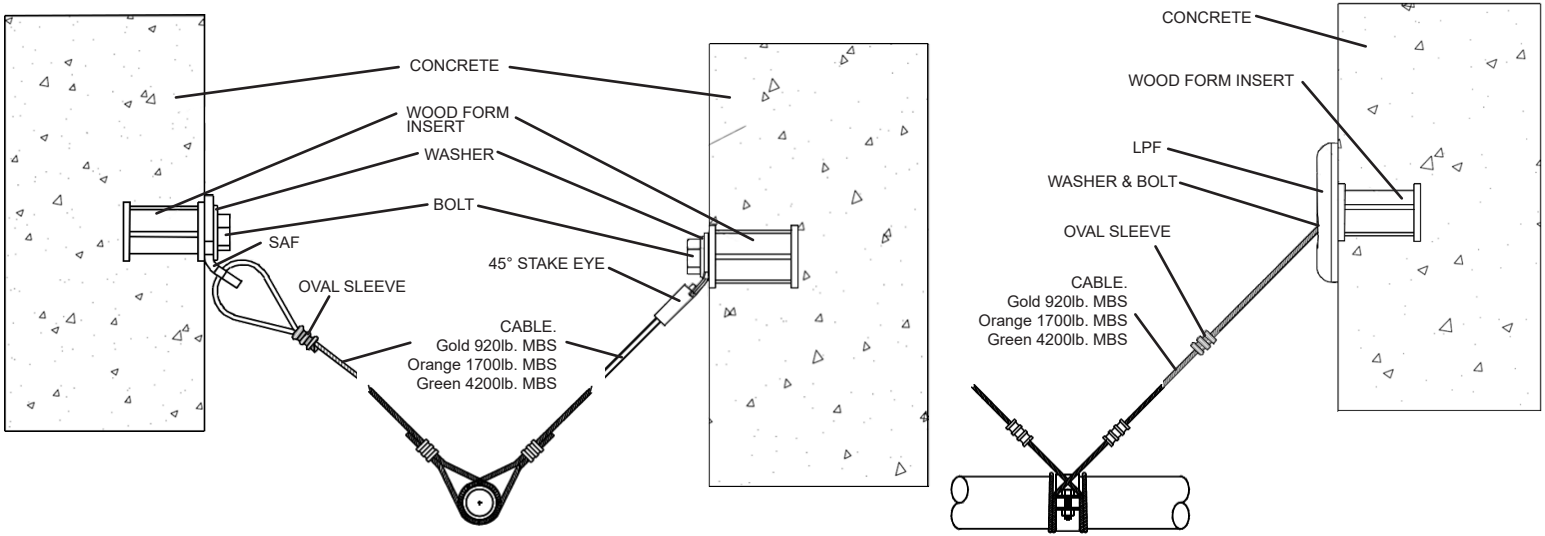

Maximum Load for Wood Form Insert in 3,000 psi (207 bar) Normal-Weight Cracked Concrete

Fastener Diameter	Fastener Min. Nom. Embedment	Min. Slab Thickness	Min. Edge Distance (in.)	LPF			SAF (All)			Stake Eye		
				30°-44°	45°-59°	60°-90°	30°-44°	45°-59°	60°-90°	30°-44°	45°-59°	60°-90°
3/8"	1.100	4	6	237 lbs.	342 lbs.	444 lbs.	207 lbs.	264 lbs.	298 lbs.	207 lbs.	264 lbs.	298 lbs.
1/2"	1.690	4	6	327 lbs.	443 lbs.	535 lbs.	272 lbs.	321 lbs.	336 lbs.	272 lbs.	321 lbs.	336 lbs.
5/8"	1.750	4	8	327 lbs.	443 lbs.	535 lbs.	272 lbs.	321 lbs.	336 lbs.	N/A	N/A	N/A
3/4"	1.750	4	8	327 lbs.	443 lbs.	535 lbs.	272 lbs.	321 lbs.	336 lbs.	N/A	N/A	N/A



INSTRUCTIONS

Load: Perpendicular to Structural Member

Angles: D (30°), E (45°), and F (60°)

Material: Wedge Anchors in 3,000 PSI (207 bar) Light Weight Cracked Concrete

Table: 18.5.12.2 (B)

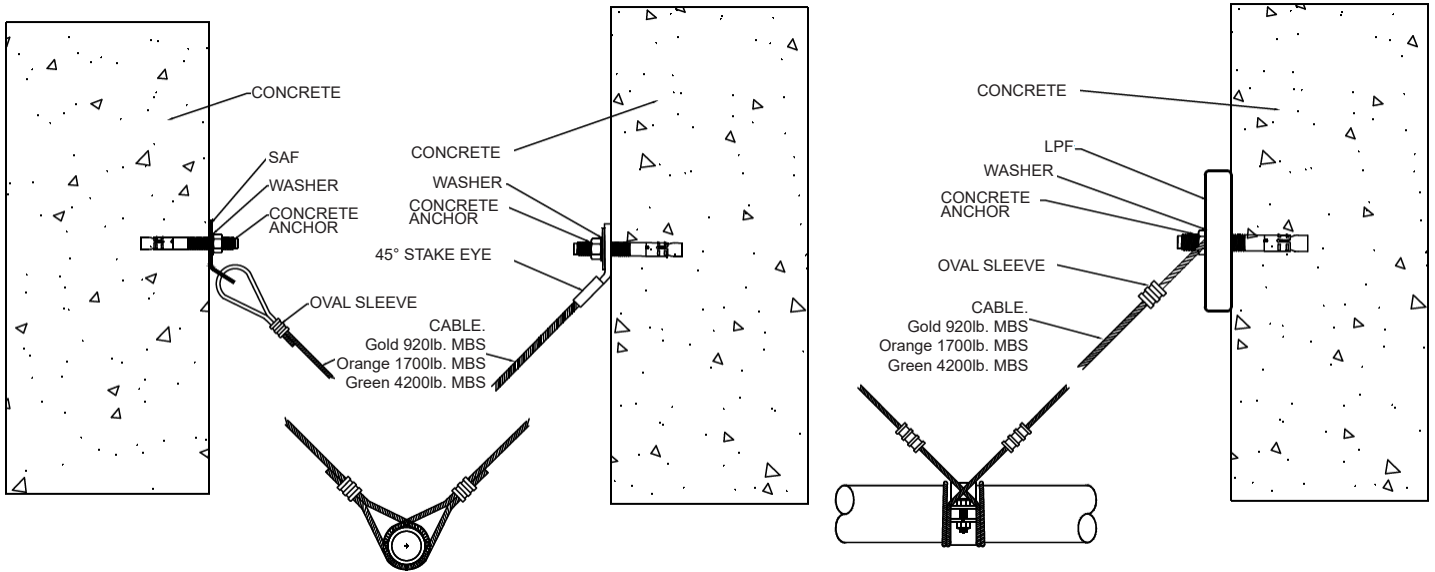

Maximum Load for Wedge Anchors in 3,000 psi (207 bar) Lightweight Cracked Concrete

Fastener Diameter	Fastener Min. Nom. Embedment	Min. Slab Thickness	Min. Edge Distance (in.)	LPF			SAF (All)			Stake Eye		
				30°-44°	45°-59°	60°-90°	30°-44°	45°-59°	60°-90°	30°-44°	45°-59°	60°-90°
3/8"	2.375	5	4	162 lbs.	216 lbs.	256 lbs.	133 lbs.	154 lbs.	157 lbs.	133 lbs.	154 lbs.	157 lbs.
1/2"	3.750	6	6	243 lbs.	314 lbs.	362 lbs.	195 lbs.	218 lbs.	209 lbs.	195 lbs.	218 lbs.	209 lbs.
5/8"	3.875	6	6	297 lbs.	394 lbs.	467 lbs.	244 lbs.	281 lbs.	286 lbs.	N/A	N/A	N/A
3/4"	4.500	7	8	424 lbs.	552 lbs.	641 lbs.	343 lbs.	386 lbs.	376 lbs.	N/A	N/A	N/A



Load: Perpendicular to Structural Member

Angles: D (30°), E (45°), and F (60°)

Material: Wedge Anchors in 4,000 PSI (276 bar) Normal Weight Cracked Concrete

Table: 18.5.12.2 (D)

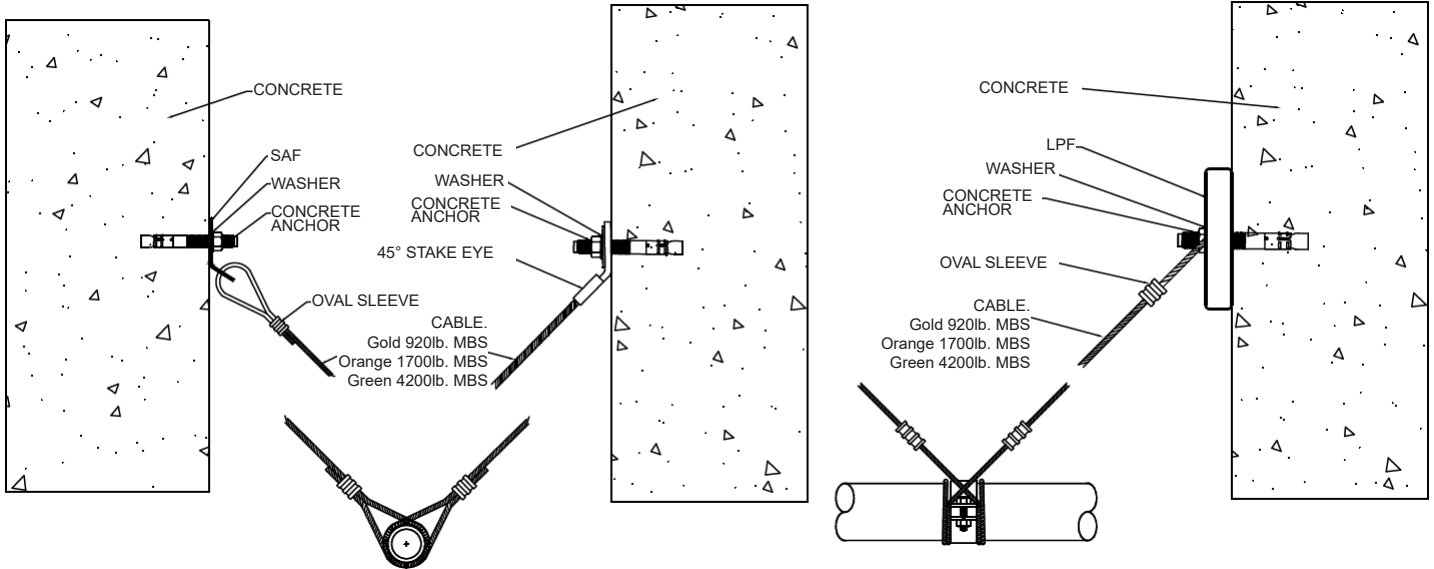

Maximum Load for Wedge Anchors in 4,000 psi (276 bar) Normal-Weight Cracked Concrete

Fastener Diameter	Fastener Min. Nom. Embedment	Min. Slab Thickness	Min. Edge Distance (in.)	LPF			SAF (All)			Stake Eye		
				30°-44°	45°-59°	60°-90°	30°-44°	45°-59°	60°-90°	30°-44°	45°-59°	60°-90°
3/8"	2.375	5	4	208 lbs.	293 lbs.	370 lbs.	178 lbs.	221 lbs.	242 lbs.	178 lbs.	221 lbs.	242 lbs.
1/2"	3.750	6	6	353 lbs.	466 lbs.	548 lbs.	289 lbs.	330 lbs.	330 lbs.	289 lbs.	330 lbs.	330 lbs.
5/8"	3.875	6	6	542 lbs.	716 lbs.	844 lbs.	444 lbs.	508 lbs.	511 lbs.	N/A	N/A	N/A
3/4"	4.500	7	8	750 lbs.	997 lbs.	1,182 lbs.	617 lbs.	711 lbs.	725 lbs.	N/A	N/A	N/A



INSTRUCTIONS

Load: Perpendicular to Structural Member

Angles: D (30°), E (45°), and F (60°)

Material: Wedge Anchors in 6,000 PSI (414 bar) Normal Weight Cracked Concrete

Table: 18.5.12.2 (E)

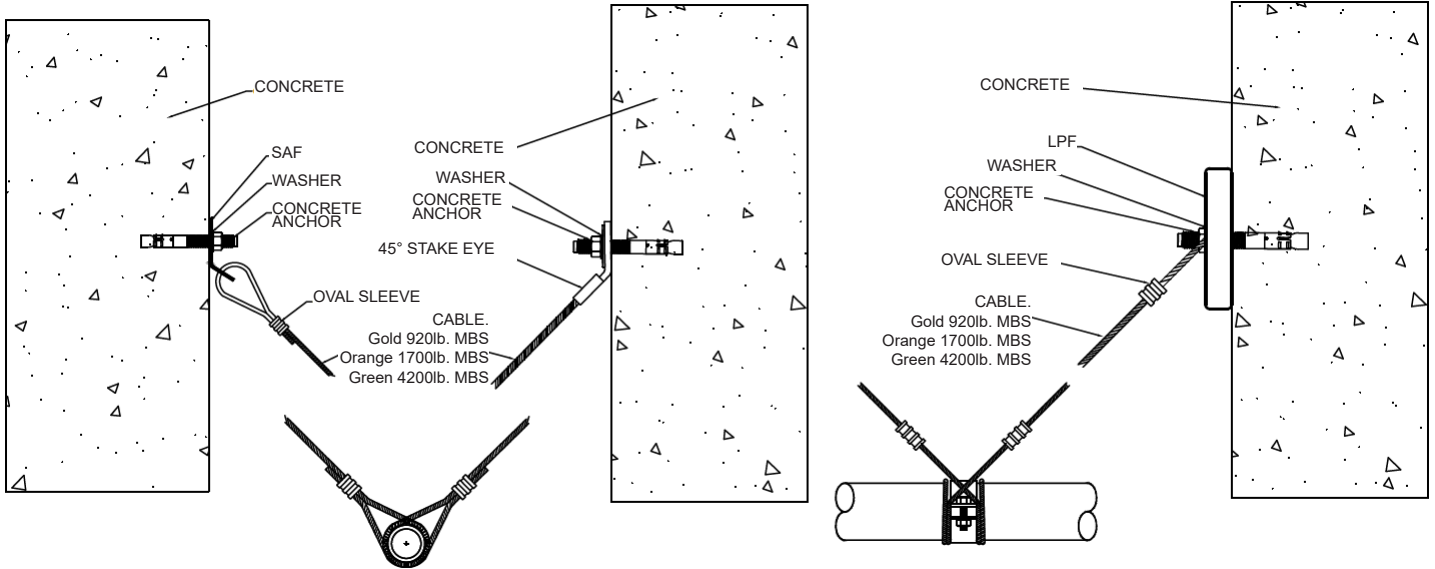

Maximum Load for Wedge Anchors in 6,000 psi (414 bar) Normal-Weight Cracked Concrete

Fastener Diameter	Fastener Min. Nom. Embedment	Min. Slab Thickness	Min. Edge Distance (in.)	LPF			SAF (All)			Stake Eye		
				30°-44°	45°-59°	60°-90°	30°-44°	45°-59°	60°-90°	30°-44°	45°-59°	60°-90°
3/8"	2.375	5	4	219 lbs.	313 lbs.	402 lbs.	190 lbs.	240 lbs.	267 lbs.	190 lbs.	240 lbs.	267 lbs.
1/2"	3.750	6	6	392 lbs.	529 lbs.	637 lbs.	326 lbs.	382 lbs.	400 lbs.	326 lbs.	382 lbs.	400 lbs.
5/8"	3.875	6	6	601 lbs.	812 lbs.	981 lbs.	500 lbs.	589 lbs.	617 lbs.	N/A	N/A	N/A
3/4"	4.500	7	8	829 lbs.	1,127 lbs.	1,370 lbs.	693 lbs.	822 lbs.	868 lbs.	N/A	N/A	N/A



Load: Perpendicular to Structural Member

Angles: D (30°), E (45°), and F (60°)

Material: Connections to Steel Using Unfinished Steel Bolts

Table: 18.5.12.2 (K)

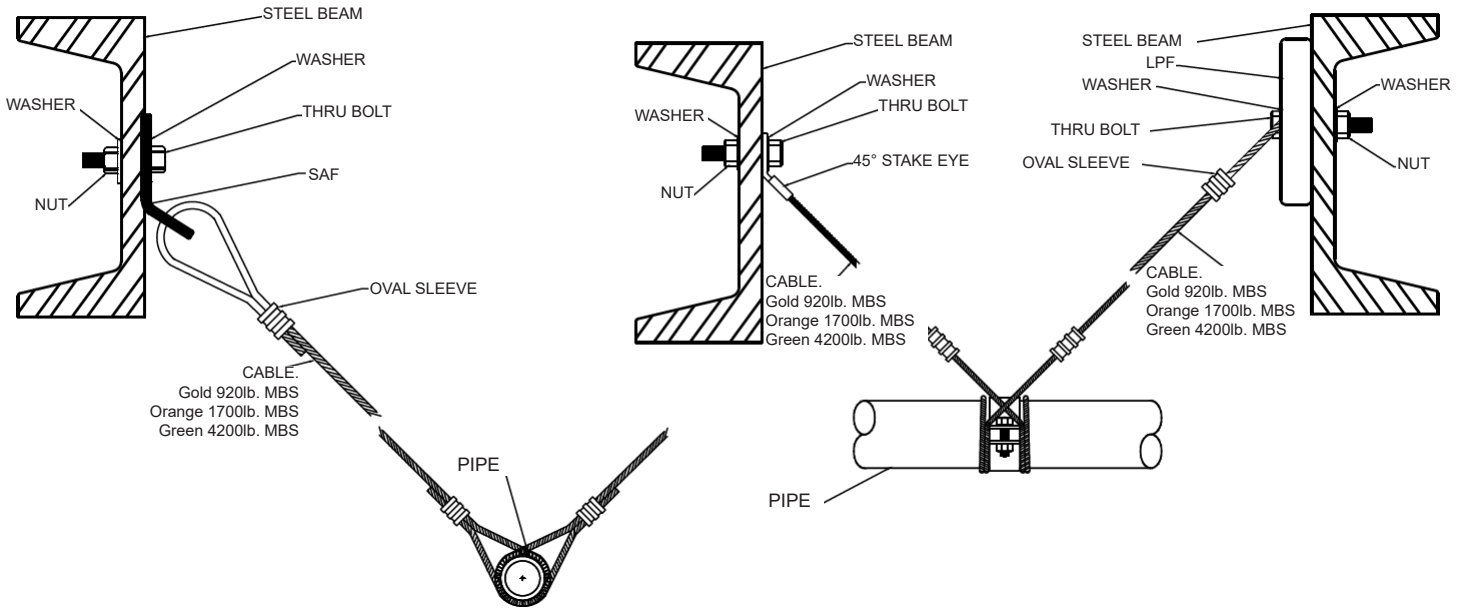

Diameter	30° - 44°	45° - 59°	60° - 90°
1/4"	300 lbs.	500 lbs.	650 lbs.
3/8"	800 lbs.	1,200 lbs.	1,550 lbs.
1/2"	1,450 lbs.	2,050 lbs.	2,850 lbs.
5/8"	2,250 lbs.	3,300 lbs.	4,400 lbs.



INSTRUCTIONS

Load: Parallel to Structural Member

Angles: G (30°), H (45°), and I (60°)

Material: Through-Bolts in Sawn Lumber or Glue-Laminated Timbers

Table: 18.5.12.2 (L)

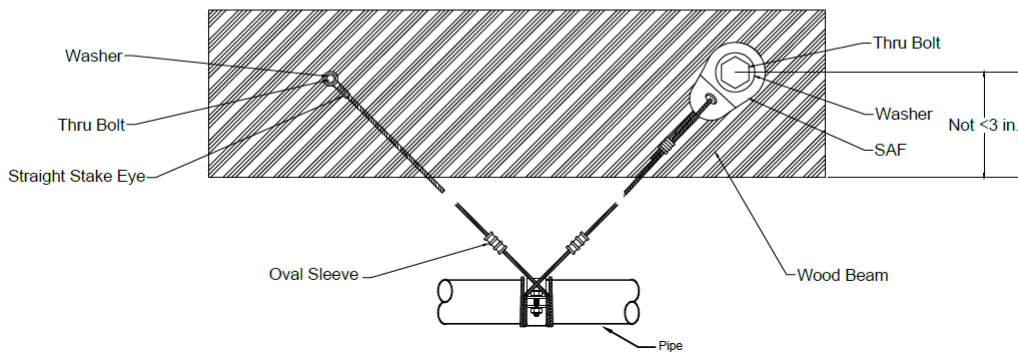
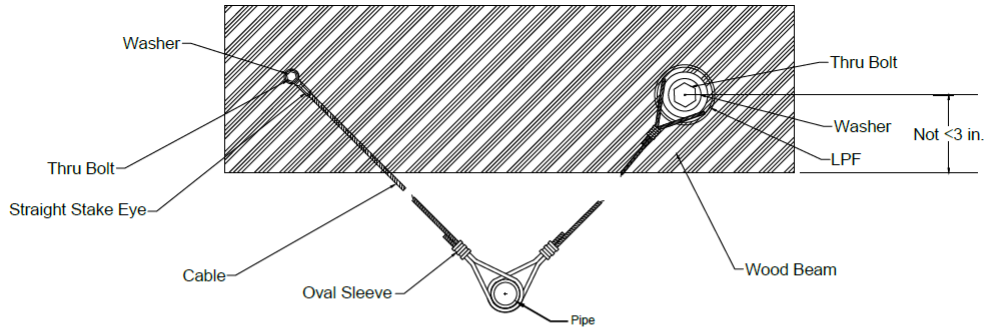

Bolt Length	1/2" Bolt Diameter			5/8" Bolt Diameter			3/4" Bolt Diameter		
	30° - 44°	45° - 59°	60° - 90°	30° - 44°	45° - 59°	60° - 90°	30° - 44°	45° - 59°	60° - 90°
1-1/2"	130 lbs.	215 lbs.	310 lbs.	155 lbs.	255 lbs.	380 lbs.	170 lbs.	300 lbs.	450 lbs.
2-1/2"	165 lbs.	275 lbs.	410 lbs.	190 lbs.	320 lbs.	495 lbs.	215 lbs.	365 lbs.	575 lbs.
3-1/2"	200 lbs.	330 lbs.	485 lbs.	235 lbs.	405 lbs.	635 lbs.	260 lbs.	455 lbs.	730 lbs.
5-1/2"	N/A	N/A	N/A	315 lbs.	515 lbs.	735 lbs.	360 lbs.	610 lbs.	925 lbs.

Above listed values based on wood with a specific gravity of 0.35. Values for other woods can be obtained by multiplying above values by factors listed in Figure 1.

Figure 1

Specific Gravity of Wood	Multiplier
0.36 - 0.49	1.17
0.50 - 0.65	1.25
0.66 - 0.73	1.50

Load: Parallel to Structural Member

Angles: G (30°), H (45°), and I (60°)

Material: Lag Screw and Lag Bolts in Wood

Table: 18.5.12.2 (M)

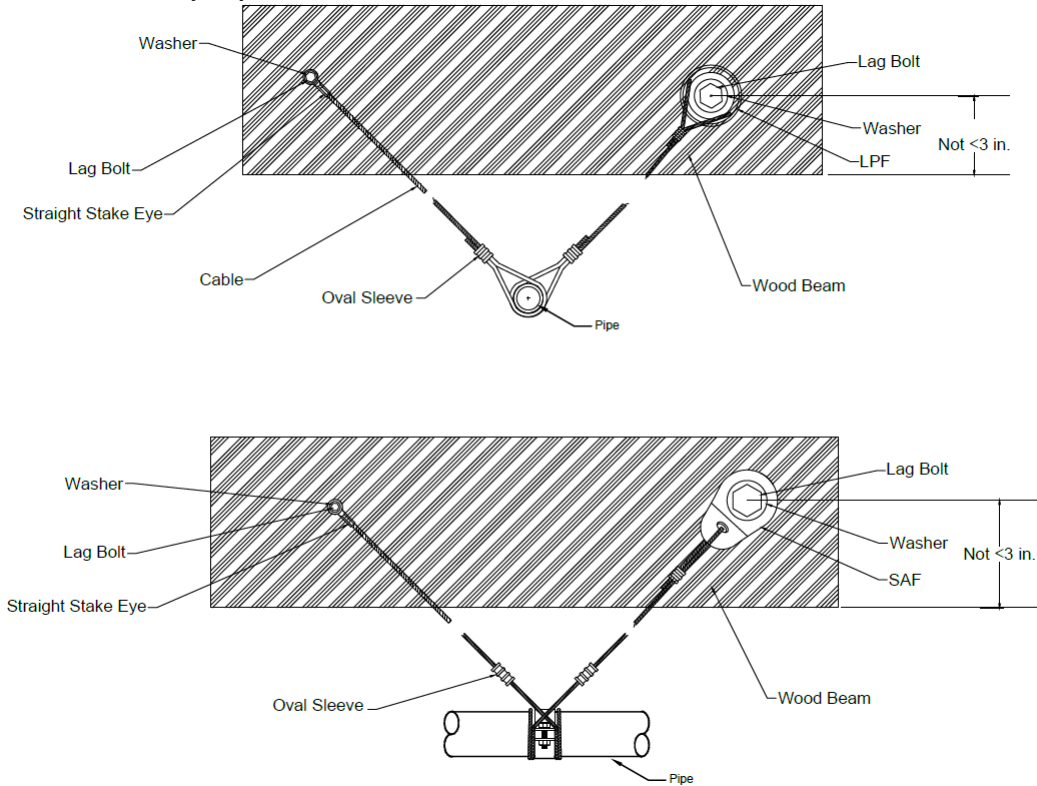

Lag Length	3/8" Lag Diameter			1/2" Lag Diameter			5/8" Lag Diameter		
	30° - 44°	45° - 59°	60° - 90°	30° - 44°	45° - 59°	60° - 90°	30° - 44°	45° - 59°	60° - 90°
3-1/2"	80 lbs.	120 lbs.	170 lbs.						
4-1/2"	80 lbs.	120 lbs.	170 lbs.	145 lbs.	230 lbs.	325 lbs.			
5-1/2"	80 lbs.	120 lbs.	170 lbs.	145 lbs.	230 lbs.	325 lbs.	195 lbs.	320 lbs.	460 lbs.
6-1/2"	80 lbs.	120 lbs.	170 lbs.	145 lbs.	230 lbs.	325 lbs.	195 lbs.	320 lbs.	460 lbs.

Above listed values based on wood with a specific gravity of 0.35. Values for other woods can be obtained by multiplying above values by factors listed in Figure 1.

Figure 1

Specific Gravity of Wood	Multiplier
0.36 - 0.49	1.17
0.50 - 0.65	1.25
0.66 - 0.73	1.50

INSTRUCTIONS

Load: Parallel to Structural Member

Angles: G (30°), H (45°), and I (60°)

Material: Wedge Anchors in 3,000 PSI (207 bar) Normal Weight Cracked Concrete

Table: 18.5.12.2 (C)

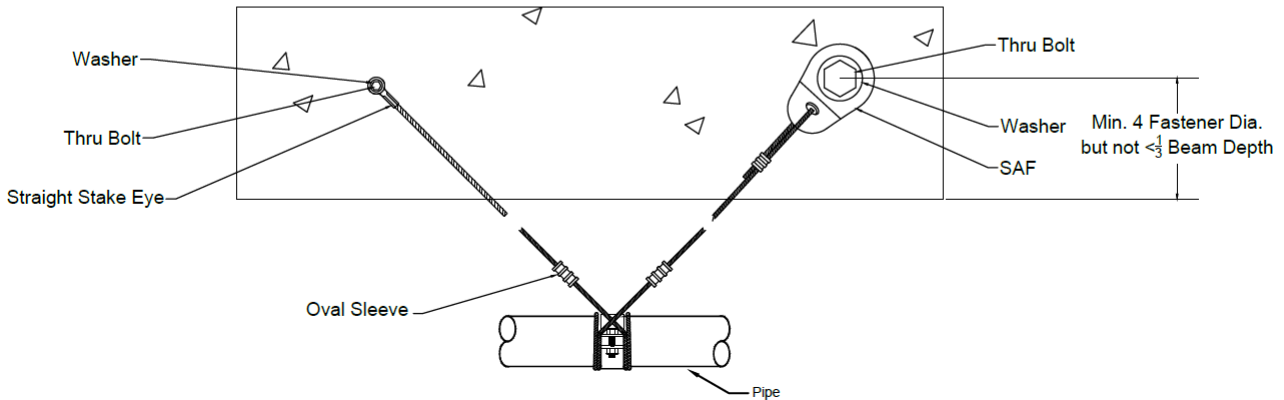
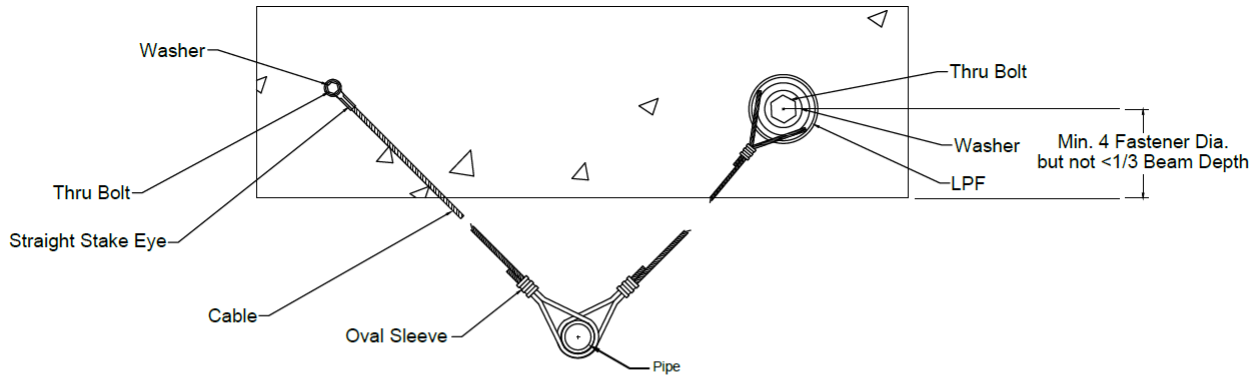

Maximum Load for Wedge Anchors in 3,000 psi (207 bar) Normal-Weight Cracked Concrete

Fastener Diameter	Fastener Min. Nom. Embedment	Min. Slab Thickness	Min. Edge Distance (in.)	LPF			SAF (All)			Stake Eye		
				30°-44°	45°-59°	60°-90°	30°-44°	45°-59°	60°-90°	30°-44°	45°-59°	60°-90°
3/8"	2.375	5	4	170 lbs.	251 lbs.	297 lbs.	147 lbs.	212 lbs.	256 lbs.	147 lbs.	212 lbs.	256 lbs.
1/2"	3.750	6	6	281 lbs.	419 lbs.	490 lbs.	233 lbs.	337 lbs.	403 lbs.	233 lbs.	337 lbs.	403 lbs.
5/8"	3.875	6	6	406 lbs.	605 lbs.	709 lbs.	341 lbs.	492 lbs.	590 lbs.	N/A	N/A	N/A
3/4"	4.500	7	8	615 lbs.	916 lbs.	1,073 lbs.	515 lbs.	744 lbs.	892 lbs.	N/A	N/A	N/A



Load: Parallel to Structural Member

Angles: G (30°), H (45°), and I (60°)

Material: Wood Form Inserts in 3,000 PSI (207 bar) Normal Weight Cracked Concrete

Table: 18.5.12.2 (H)

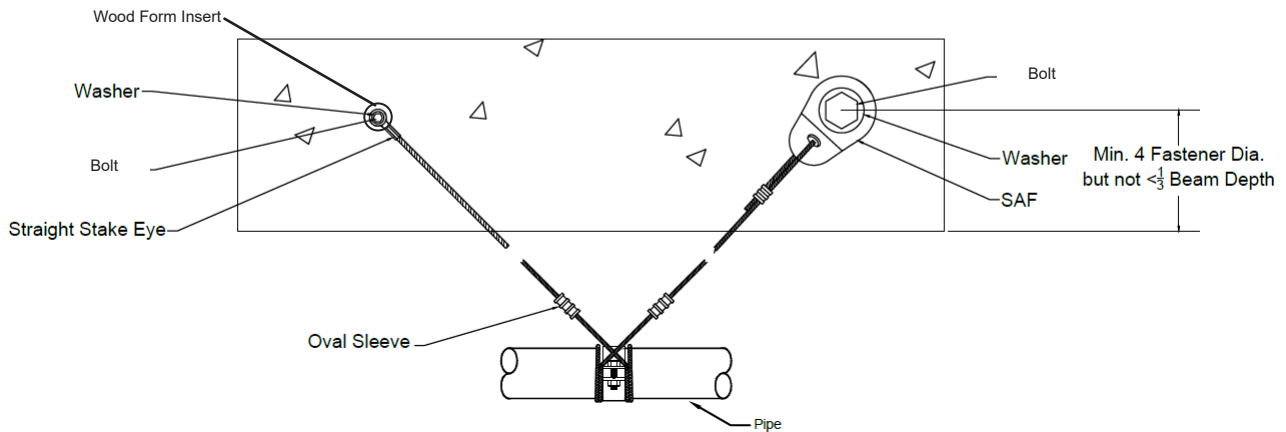
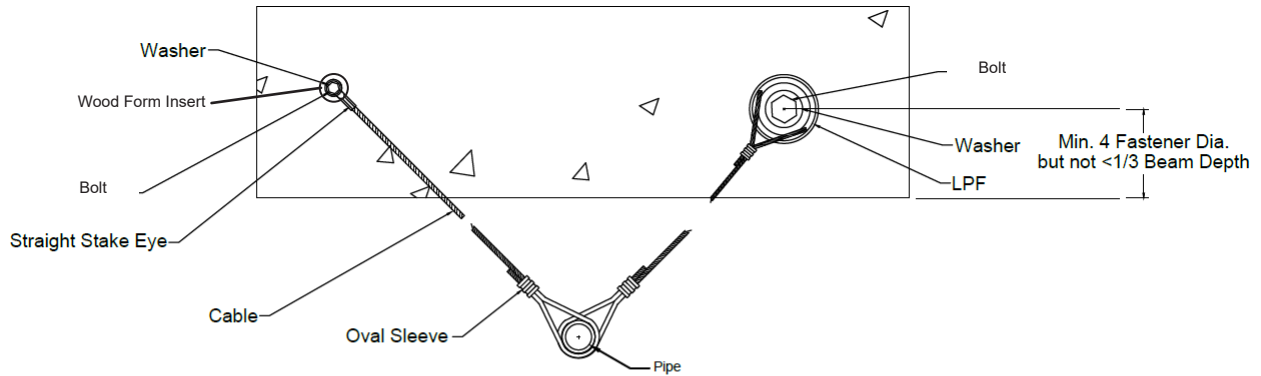

Maximum Load for Wood Form Inserts in 3,000 psi (207 bar) Normal-Weight Cracked Concrete

Fastener Diameter	Fastener Min. Nom. Embedment	Min. Slab Thickness	Min. Edge Distance (in.)	LPF			SAF (All)			Stake Eye		
				30°-44°	45°-59°	60°-90°	30°-44°	45°-59°	60°-90°	30°-44°	45°-59°	60°-90°
3/8"	1.100	4	6	205 lbs.	300 lbs.	357 lbs.	182 lbs.	261 lbs.	315 lbs.	182 lbs.	261 lbs.	315 lbs.
1/2"	1.690	4	6	282 lbs.	418 lbs.	492 lbs.	240 lbs.	347 lbs.	416 lbs.	240 lbs.	347 lbs.	416 lbs.
5/8"	1.750	4	8	282 lbs.	418 lbs.	492 lbs.	240 lbs.	347 lbs.	416 lbs.	N/A	N/A	N/A
3/4"	1.750	4	8	282 lbs.	418 lbs.	492 lbs.	240 lbs.	347 lbs.	416 lbs.	N/A	N/A	N/A



INSTRUCTIONS

Load: Parallel to Structural Member

Angles: G (30°), H (45°), and I (60°)

Material: Wedge Anchors in 3,000 PSI (207 bar) Light Weight Cracked Concrete

Table: 18.5.12.2 (B)

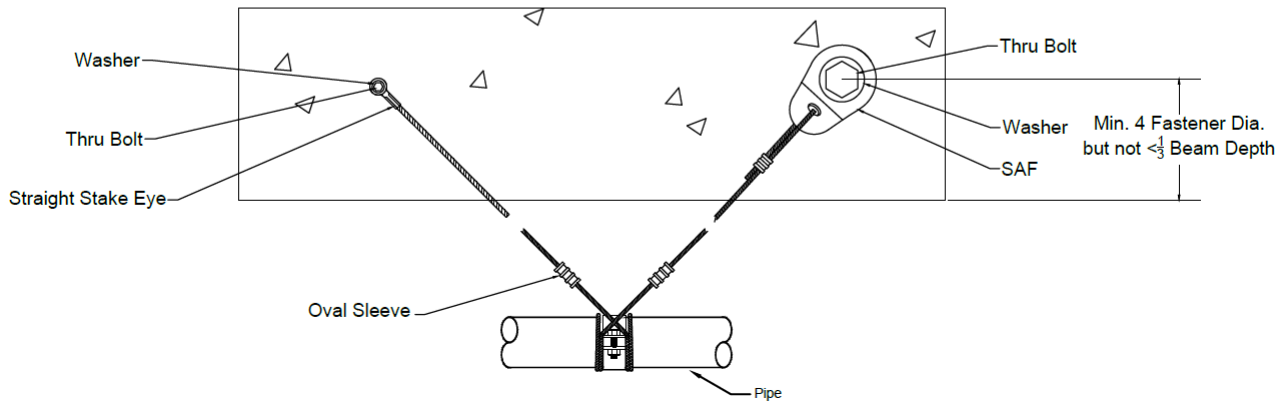
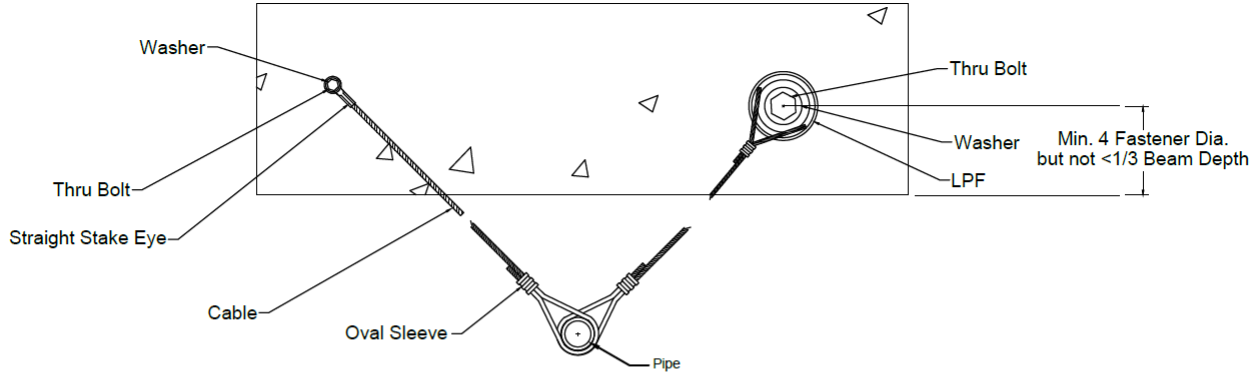

Maximum Load for Wedge Anchors in 3,000 psi (207 bar) Lightweight Cracked Concrete

Fastener Diameter	Fastener Min. Nom. Embedment	Min. Slab Thickness	Min. Edge Distance (in.)	LPF			SAF (All)			Stake Eye		
				30°-44°	45°-59°	60°-90°	30°-44°	45°-59°	60°-90°	30°-44°	45°-59°	60°-90°
3/8"	2.375	5	4	139 lbs.	208 lbs.	244 lbs.	117 lbs.	170 lbs.	204 lbs.	117 lbs.	170 lbs.	204 lbs.
1/2"	3.750	6	6	209 lbs.	312 lbs.	365 lbs.	172 lbs.	250 lbs.	299 lbs.	172 lbs.	250 lbs.	299 lbs.
5/8"	3.875	6	6	255 lbs.	380 lbs.	446 lbs.	215 lbs.	311 lbs.	373 lbs.	N/A	N/A	N/A
3/4"	4.500	7	8	365 lbs.	544 lbs.	636 lbs.	303 lbs.	438 lbs.	525 lbs.	N/A	N/A	N/A



Load: Parallel to Structural Member

Angles: G (30°), H (45°), and I (60°)

Material: Wedge Anchors in 4,000 PSI (276 bar) Normal Weight Cracked Concrete

Table: 18.5.12.2 (D)

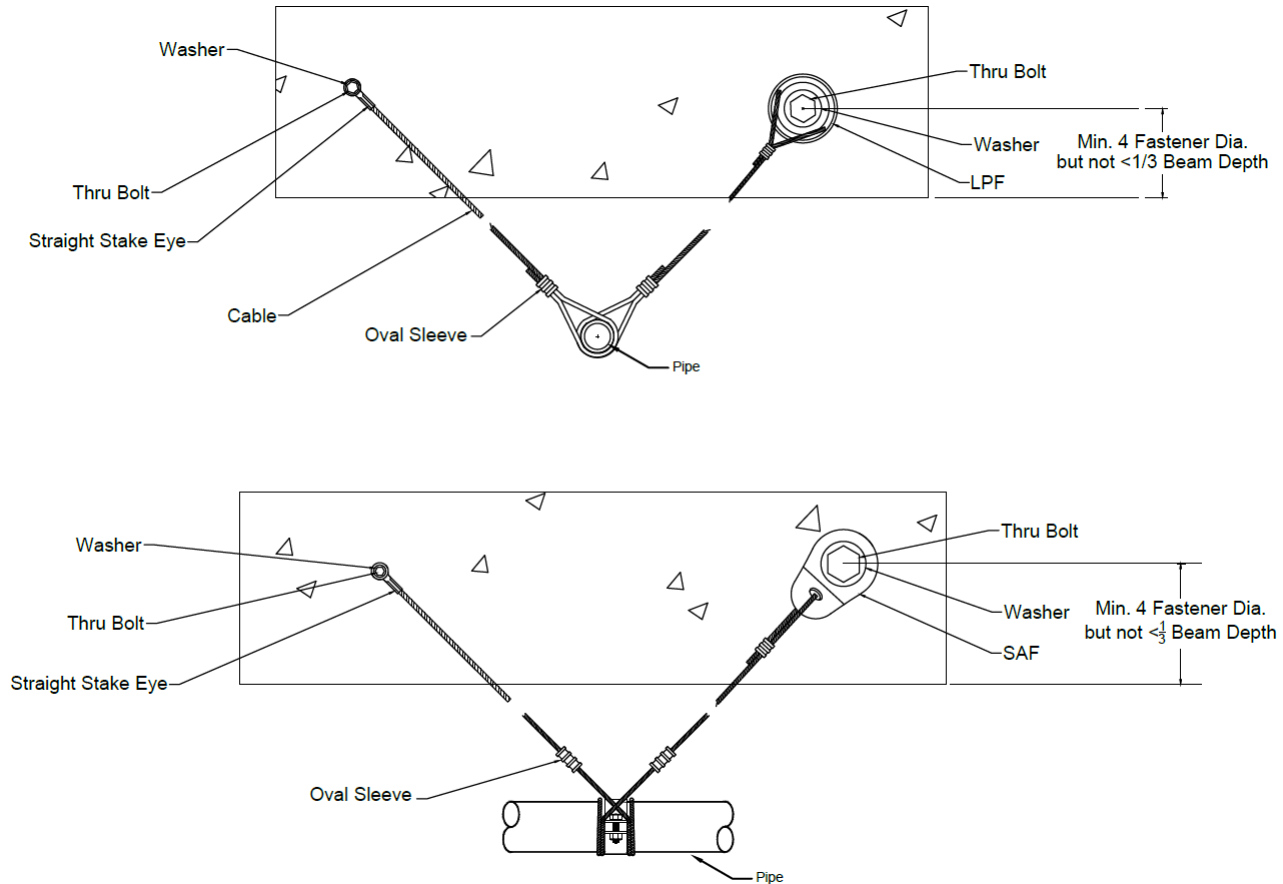

Maximum Load for Wedge Anchors in 4,000 psi (276 bar) Normal-Weight Cracked Concrete

Fastener Diameter	Fastener Min. Nom. Embedment	Min. Slab Thickness	Min. Edge Distance (in.)	LPF			SAF (All)			Stake Eye		
				30°-44°	45°-59°	60°-90°	30°-44°	45°-59°	60°-90°	30°-44°	45°-59°	60°-90°
3/8"	2.375	5	4	179 lbs.	264 lbs.	313 lbs.	157 lbs.	226 lbs.	272 lbs.	157 lbs.	226 lbs.	272 lbs.
1/2"	3.750	6	6	304 lbs.	453 lbs.	531 lbs.	255 lbs.	368 lbs.	442 lbs.	255 lbs.	368 lbs.	442 lbs.
5/8"	3.875	6	6	467 lbs.	694 lbs.	814 lbs.	392 lbs.	566 lbs.	678 lbs.	N/A	N/A	N/A
3/4"	4.500	7	8	646 lbs.	959 lbs.	1,125 lbs.	544 lbs.	786 lbs.	942 lbs.	N/A	N/A	N/A



INSTRUCTIONS

Load: Parallel to Structural Member

Angles: G (30°), H (45°), and I (60°)

Material: Wedge Anchors in 6,000 PSI (414 bar) Normal Weight Cracked Concrete

Table: 18.5.12.2 (E)

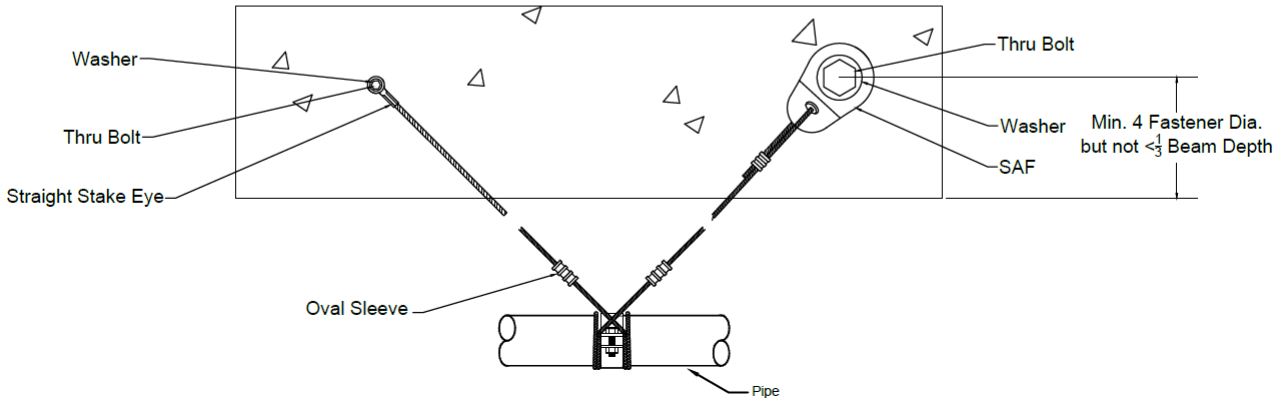
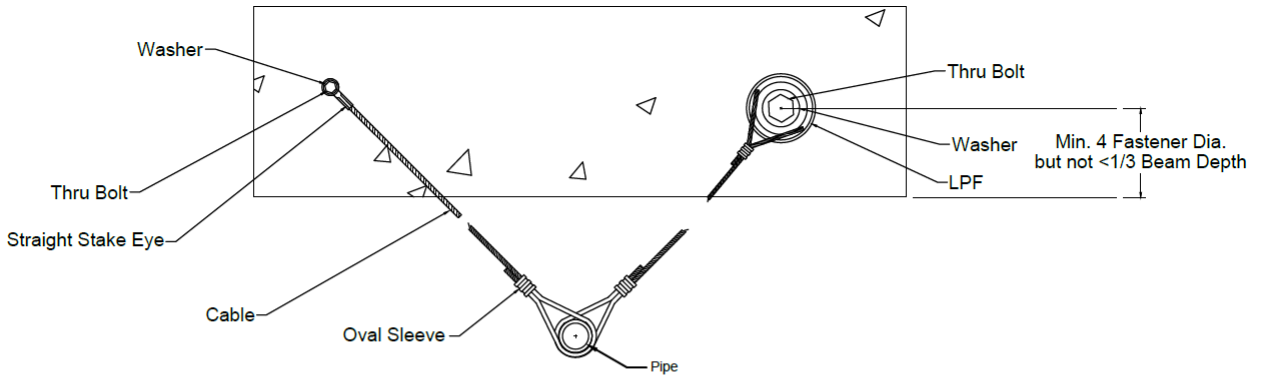

Maximum Load for Wedge Anchors in 6,000 psi (414 bar) Normal-Weight Cracked Concrete

Fastener Diameter	Fastener Min. Nom. Embedment	Min. Slab Thickness	Min. Edge Distance (in.)	LPF			SAF (All)			Stake Eye		
				30°-44°	45°-59°	60°-90°	30°-44°	45°-59°	60°-90°	30°-44°	45°-59°	60°-90°
3/8"	2.375	5	4	189 lbs.	277 lbs.	329 lbs.	167 lbs.	240 lbs.	289 lbs.	167 lbs.	240 lbs.	289 lbs.
1/2"	3.750	6	6	337 lbs.	500 lbs.	589 lbs.	287 lbs.	414 lbs.	498 lbs.	287 lbs.	414 lbs.	498 lbs.
5/8"	3.875	6	6	517 lbs.	766 lbs.	902 lbs.	441 lbs.	636 lbs.	764 lbs.	N/A	N/A	N/A
3/4"	4.500	7	8	714 lbs.	1,055 lbs.	1,243 lbs.	611 lbs.	881 lbs.	1,058 lbs.	N/A	N/A	N/A



Load: Parallel to Structural Member

Angles: G (30°), H (45°), and I (60°)

Material: Connection to Steel Using Unfinished Steel Bolts

Table: 18.5.12.2 (K)

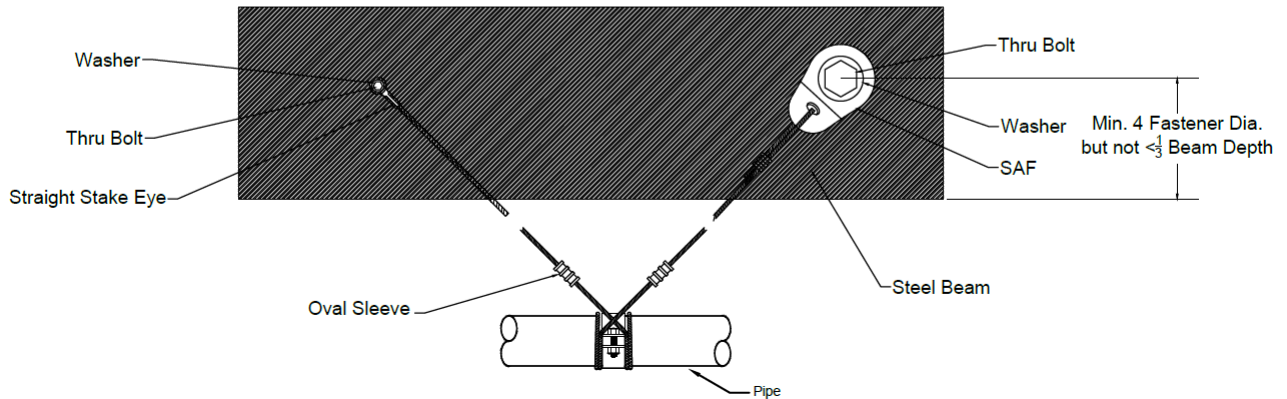
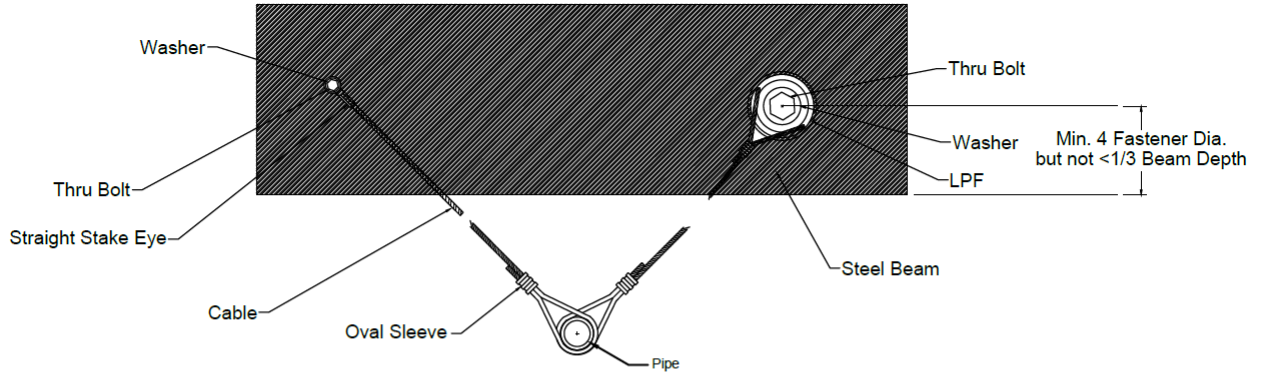

Diameter	30° - 44°	45° - 59°	60° - 90°
1/4"	325 lbs.	458 lbs.	565 lbs.
3/8"	735 lbs.	1,035 lbs.	1,278 lbs.
1/2"	1,300 lbs.	1,830 lbs.	2,260 lbs.
5/8"	2,045 lbs.	2,880 lbs.	3,557 lbs.



INSTRUCTIONS

Load: Perpendicular to Structural Member

Angles: A (30°), B (45°), and C (60°)

Material: Cable looped around top member of bar joist

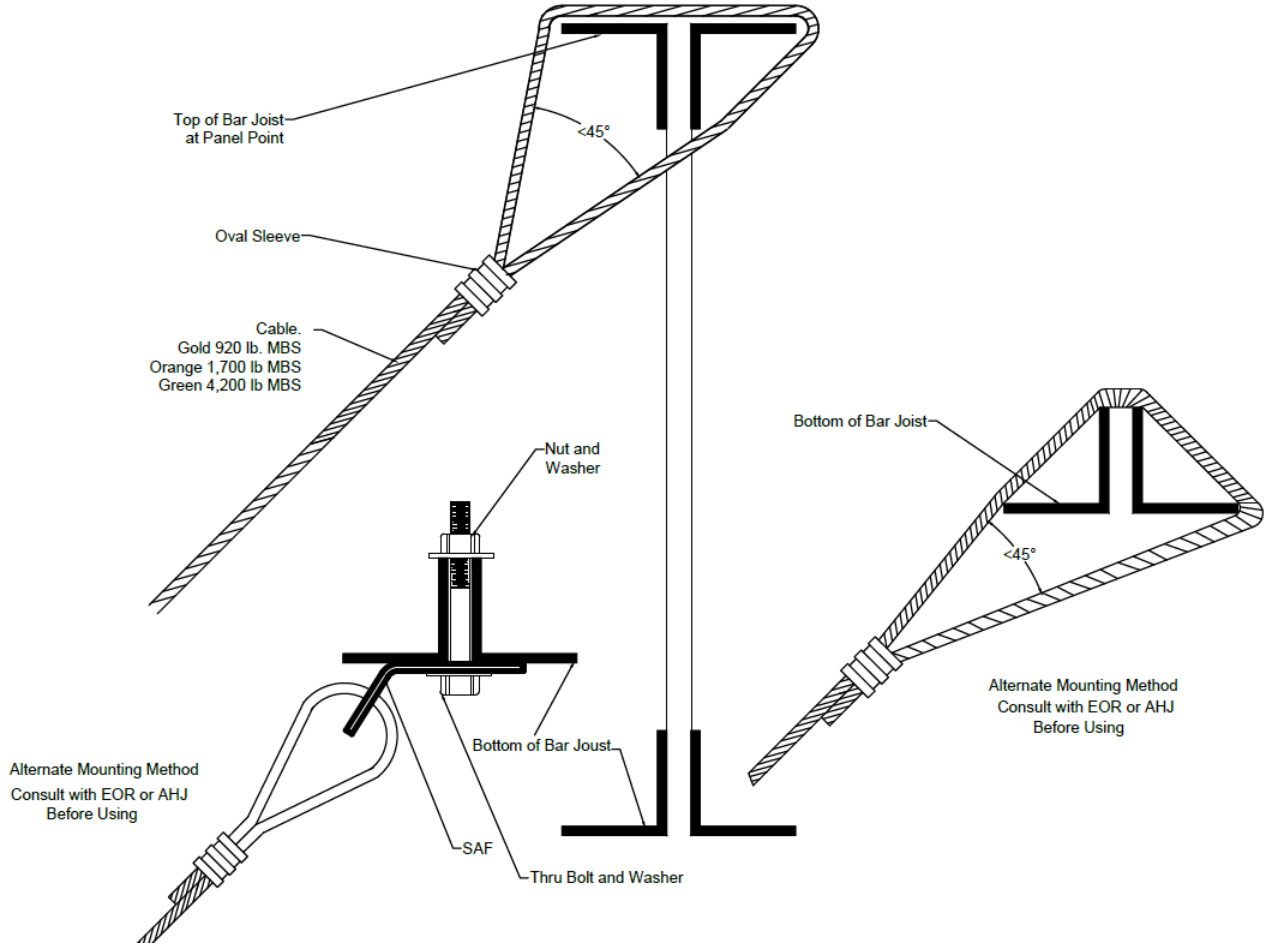

Cable Color	Load Rating	30° - 44°	45° - 59°	60° - 90°
Gold	418 lbs.	209 lbs.	295 lbs.	361 lbs.
Orange	770 lbs.	385 lbs.	544 lbs.	666 lbs.
Green	1,900 lbs.	950 lbs.	1,343 lbs.	1,645 lbs.
Black	3,180 lbs.	1,590 lbs.	2,248 lbs.	2,753 lbs.



Typical Riser Bracing Angle Roof Installation

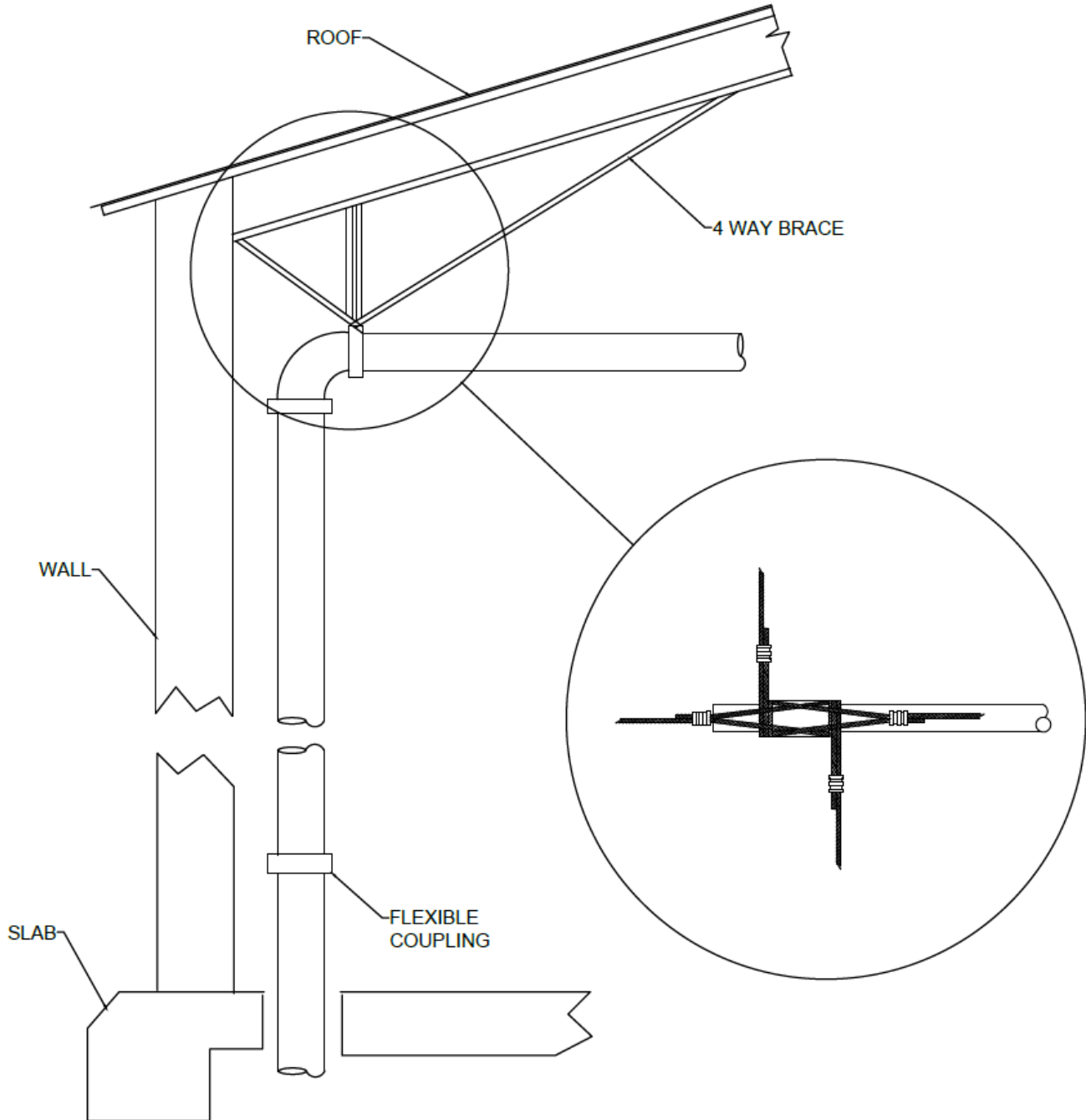

Typical Riser Bracing Flat Roof Installation

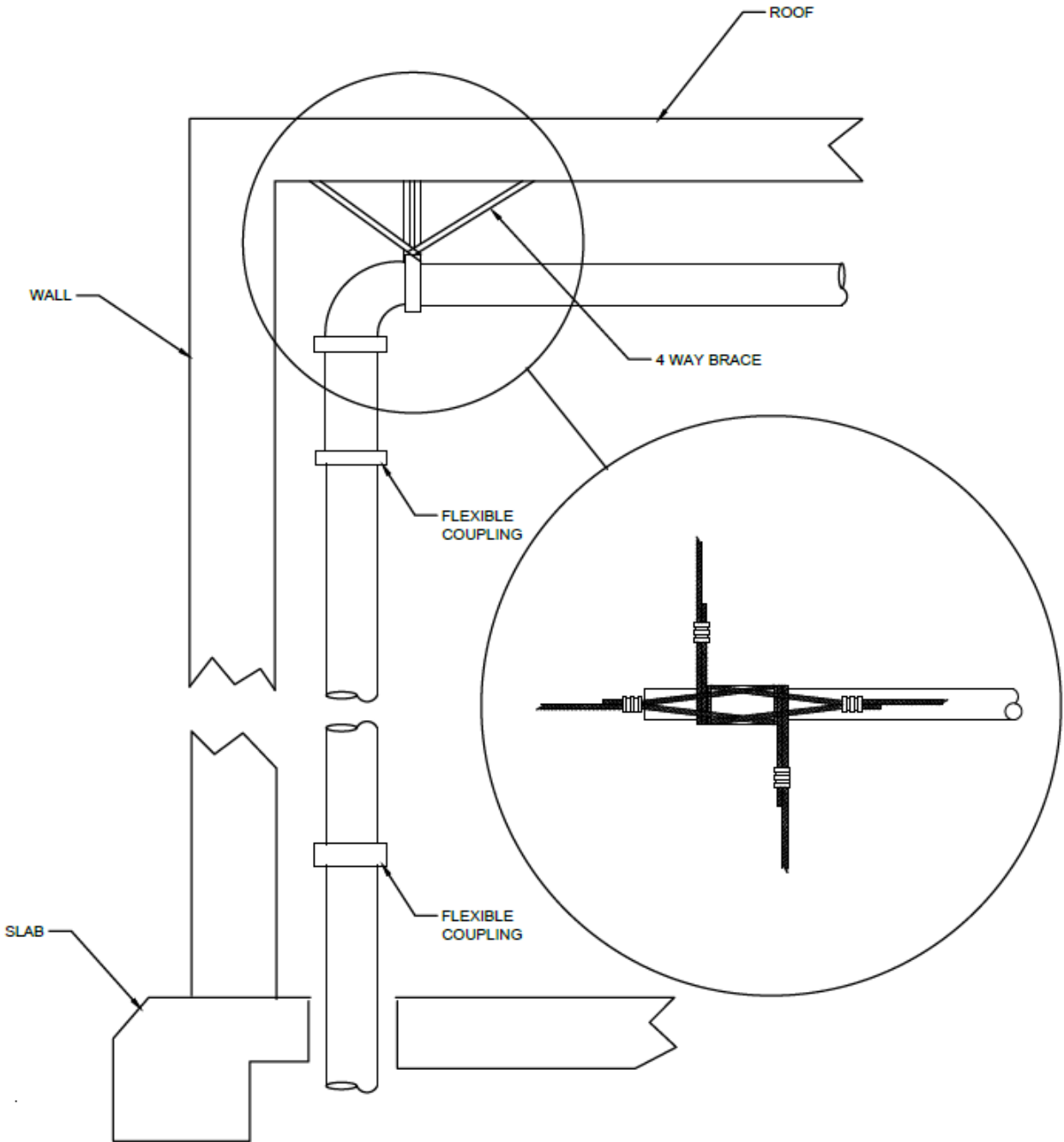

Typical Riser Bracing Wall Installation

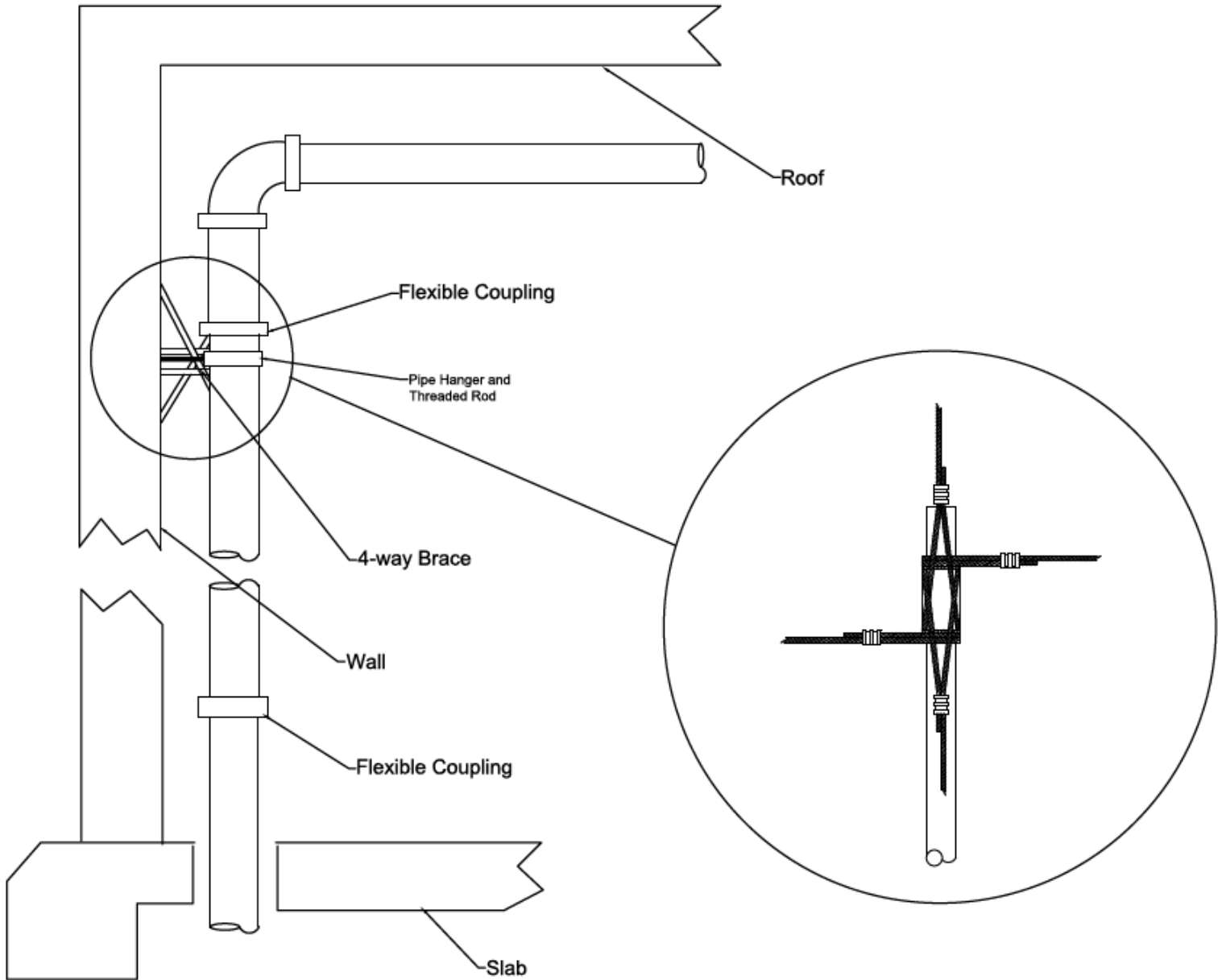

Clevis Hanger

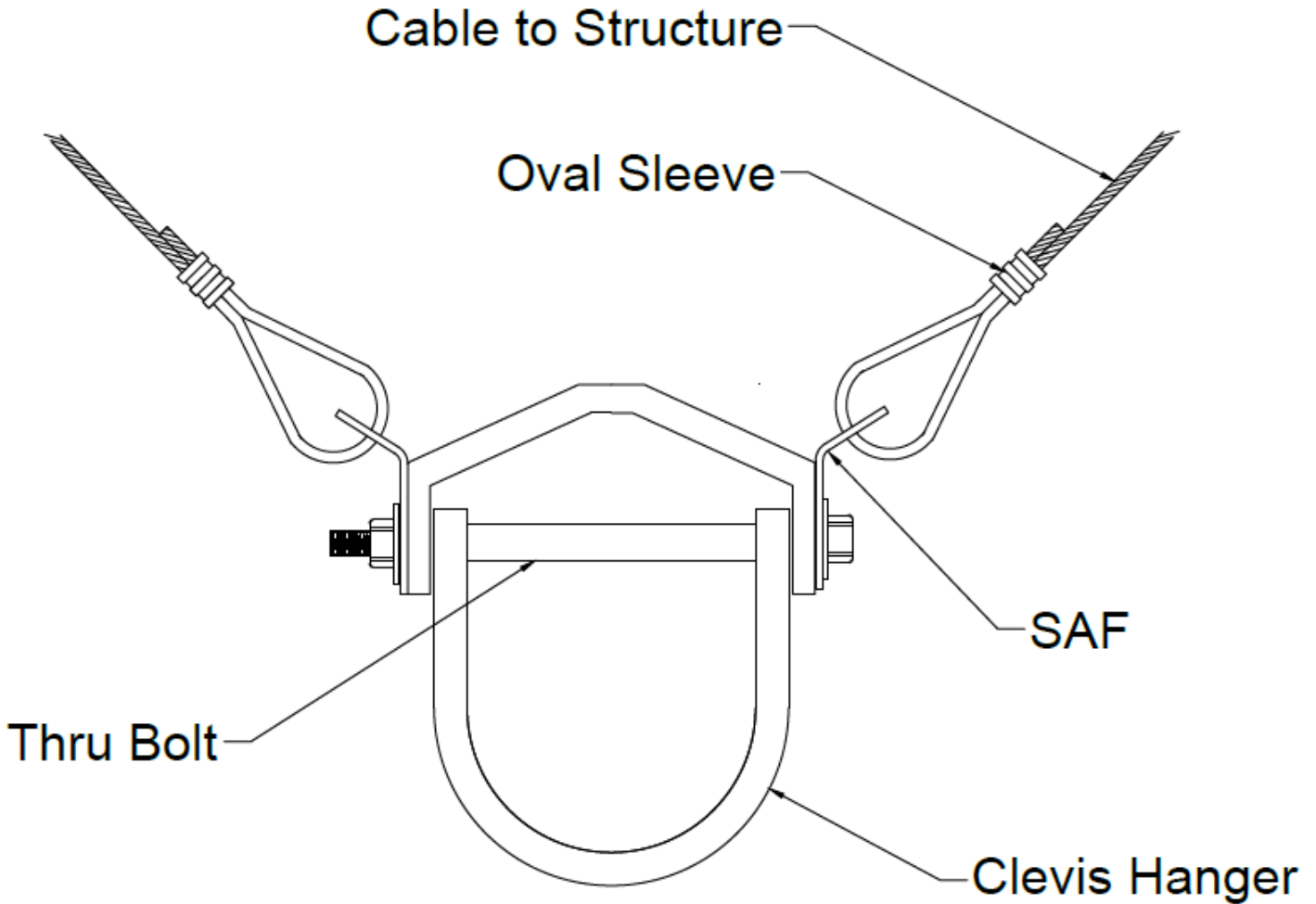

Lateral Bracing Option. Consult EOR or AHJ
before using



Pipe Hanger

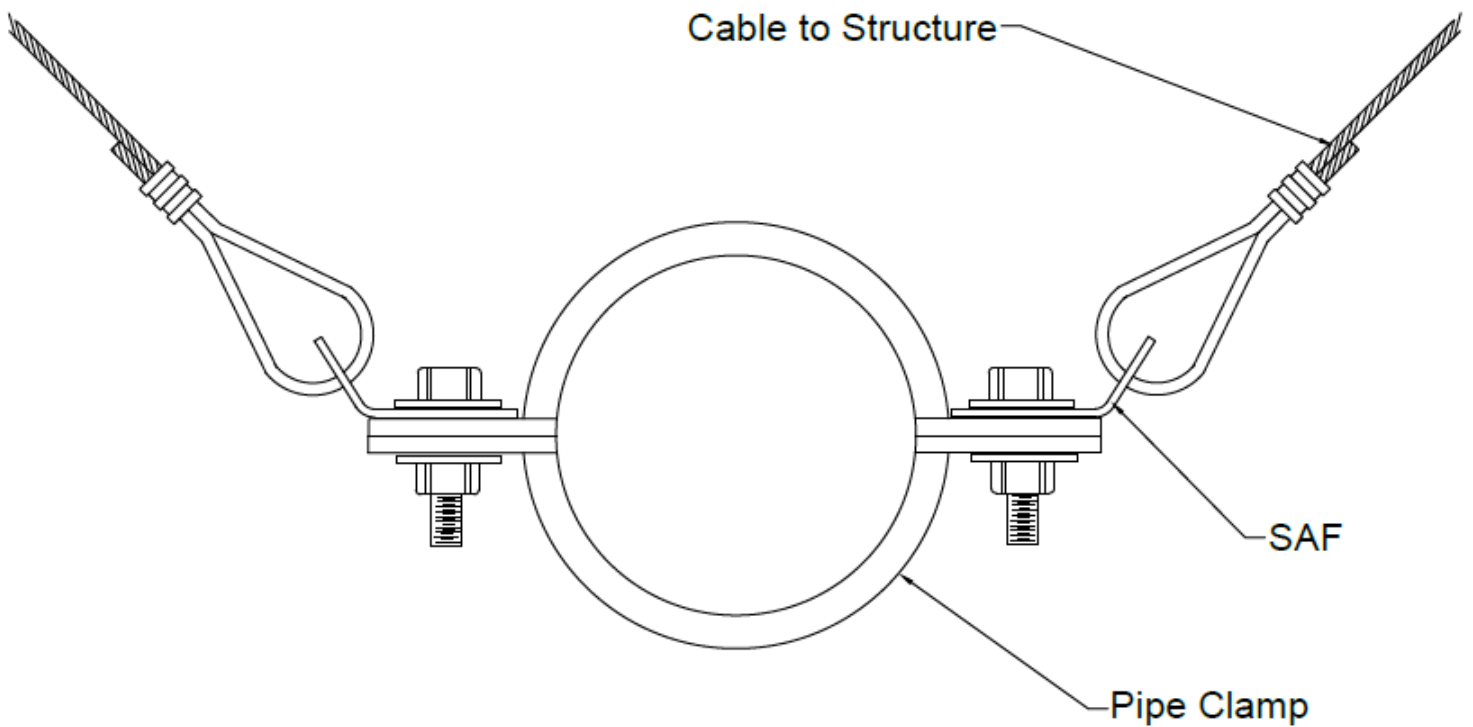

Lateral Bracing Option. Consult EOR or AHJ
 before using



Appendix

Interpreting Maximum Horizontal Load Allowed on Weakest Components of Brace Assembly	
Brace Angle	Maximum Horizontal Load
30 to 44 Degrees from Vertical	Divide Listed Load Rating by 2,000
45 to 59 Degrees from Vertical	Divide Listed Load Rating by 1,414
60 to 89 Degrees from Vertical	Divide Listed Load Rating by 1,155
90 Degrees from Vertical	Use Listed Load Rated

The load applied to a bracing element, (the brace, fasteners, connectors and structure) are derived from standard calculations. The above table is part of those calculations. Example:

The Orange cable supplied by Loos & Co., Inc. has a certified minimum break strength of 1,700 pounds. The listed load rating is 1,700 pounds divided by a safety factor of 2.2, or 770 pounds.

Depending on the angle which is used in the installation, the listed load rating of 770 pounds is reduced again by the factor in the above table. That would allow an applied load of 770 pounds divided by 2 for a 30° installation angle, or 385 pounds.

APPENDIX

Maximum Load for Wedge Anchors in 3000 psi (207 bar) Lightweight Cracked Concrete on Metal Deck

PART	ANCHOR DIA.	MIN. NOM. EMBEDMENT (in.)	MIN. SLAB THICKNESS (in.)	MAX. FLUTE CENTER OFFSET (in.)	ORIENTATION 1			ORIENTATION 2			ORIENTATION 3		
					30°	45°	60°	30°	45°	60°	30°	45°	60°
LPF-3/8	3/8"	2.375	6.25	1	123	183	233	N/A	N/A	N/A	N/A	N/A	N/A
LPF-1/2	1/2"	3.750	6.25	1	147	231	310	N/A	N/A	N/A	N/A	N/A	N/A
LPF-5/8	5/8"	3.875	6.25	1	188	292	387	N/A	N/A	N/A	N/A	N/A	N/A
LPF-3/4	3/4"	4.500	6.25	1	255	380	486	N/A	N/A	N/A	N/A	N/A	N/A

PART	ANCHOR DIA.	MIN. NOM. EMBEDMENT (in.)	MIN. SLAB THICKNESS (in.)	MAX. FLUTE CENTER OFFSET (in.)	ORIENTATION 1			ORIENTATION 2			ORIENTATION 3		
					30°	45°	60°	30°	45°	60°	30°	45°	60°
SAF-3/8	3/8"	2.375	6.25	1	79	133	193	N/A	N/A	N/A	N/A	N/A	N/A
SAF-1/2	1/2"	3.750	6.25	1	86	160	247	N/A	N/A	N/A	N/A	N/A	N/A
SAF-5/8	5/8"	3.875	6.25	1	113	204	311	N/A	N/A	N/A	N/A	N/A	N/A
SAF-3/4	3/4"	4.500	6.25	1	165	275	402	N/A	N/A	N/A	N/A	N/A	N/A

PART	ANCHOR DIA.	MIN. NOM. EMBEDMENT (in.)	MIN. SLAB THICKNESS (in.)	MAX. FLUTE CENTER OFFSET (in.)	ORIENTATION 1			ORIENTATION 2			ORIENTATION 3		
					30°	45°	60°	30°	45°	60°	30°	45°	60°
SAFR-3/8	3/8"	2.375	6.25	1	79	133	193	N/A	N/A	N/A	N/A	N/A	N/A
SAFR-1/2	1/2"	3.750	6.25	1	86	160	247	N/A	N/A	N/A	N/A	N/A	N/A
SAFR-5/8	5/8"	3.875	6.25	1	113	204	311	N/A	N/A	N/A	N/A	N/A	N/A

PART	ANCHOR DIA.	MIN. NOM. EMBEDMENT (in.)	MIN. SLAB THICKNESS (in.)	MAX. FLUTE CENTER OFFSET (in.)	ORIENTATION 1			ORIENTATION 2			ORIENTATION 3		
					30°	45°	60°	30°	45°	60°	30°	45°	60°
SAF2-3/8	3/8"	2.375	6.25	1	79	133	193	N/A	N/A	N/A	N/A	N/A	N/A
SAF2-1/2	1/2"	3.750	6.25	1	86	160	247	N/A	N/A	N/A	N/A	N/A	N/A
SAF2-5/8	5/8"	3.875	6.25	1	113	204	311	N/A	N/A	N/A	N/A	N/A	N/A
SAF2-3/4	3/4"	4.500	6.25	1	165	275	402	N/A	N/A	N/A	N/A	N/A	N/A

PART	ANCHOR DIA.	MIN. NOM. EMBEDMENT (in.)	MIN. SLAB THICKNESS (in.)	MAX. FLUTE CENTER OFFSET (in.)	ORIENTATION 1			ORIENTATION 2			ORIENTATION 3		
					30°	45°	60°	30°	45°	60°	30°	45°	60°
SAF2R-3/8	3/8"	2.375	6.25	1	79	133	193	N/A	N/A	N/A	N/A	N/A	N/A
SAF2R-1/2	1/2"	3.750	6.25	1	86	160	247	N/A	N/A	N/A	N/A	N/A	N/A
SAF2R-5/8	5/8"	3.875	6.25	1	113	204	311	N/A	N/A	N/A	N/A	N/A	N/A

PART	ANCHOR DIA.	MIN. NOM. EMBEDMENT (in.)	MIN. SLAB THICKNESS (in.)	MAX. FLUTE CENTER OFFSET (in.)	ORIENTATION 1			ORIENTATION 2			ORIENTATION 3		
					30°	45°	60°	30°	45°	60°	30°	45°	60°
GO-3B	3/8"	2.375	6.25	1	79	133	193	N/A	N/A	N/A	N/A	N/A	N/A
OR-3B													
GR-3B													
OR-4B	1/2"	3.750	6.25	1	86	160	247	N/A	N/A	N/A	N/A	N/A	N/A
GR-4B													

Maximum Load for Wedge Anchors in 3000 psi (207 bar) Lightweight Cracked Concrete

PART	ANCHOR DIA.	MIN. NOM. EMBEDMENT (in.)	MIN. SLAB THICKNESS (in.)	MIN. EDGE DISTANCE (in.)	ORIENTATION 1			ORIENTATION 2			ORIENTATION 3		
					30°	45°	60°	30°	45°	60°	30°	45°	60°
LPF-3/8	3/8"	2.375	5	4	142	216	280	162	216	256	139	208	244
LPF-1/2	1/2"	3.750	6	6	200	314	419	243	314	362	209	312	365
LPF-5/8	5/8"	3.875	6	6	259	394	512	297	394	467	255	380	446
LPF-3/4	3/4"	4.500	7	8	356	552	731	424	552	641	365	544	636

PART	ANCHOR DIA.	MIN. NOM. EMBEDMENT (in.)	MIN. SLAB THICKNESS (in.)	MIN. EDGE DISTANCE (in.)	ORIENTATION 1			ORIENTATION 2			ORIENTATION 3		
					30°	45°	60°	30°	45°	60°	30°	45°	60°
SAF-3/8	3/8"	2.375	5	4	89	154	229	133	154	157	117	170	204
SAF-1/2	1/2"	3.750	6	6	119	218	335	195	218	209	172	250	299
SAF-5/8	5/8"	3.875	6	6	163	281	418	244	281	286	215	311	373
SAF-3/4	3/4"	4.500	7	8	214	386	588	343	386	376	303	438	525

PART	ANCHOR DIA.	MIN. NOM. EMBEDMENT (in.)	MIN. SLAB THICKNESS (in.)	MIN. EDGE DISTANCE (in.)	ORIENTATION 1			ORIENTATION 2			ORIENTATION 3		
					30°	45°	60°	30°	45°	60°	30°	45°	60°
SAFR-3/8	3/8"	2.375	5	4	89	154	229	133	154	157	117	170	204
SAFR-1/2	1/2"	3.750	6	6	119	218	335	195	218	209	172	250	299
SAFR-5/8	5/8"	3.875	6	6	163	281	418	244	281	286	215	311	373

PART	ANCHOR DIA.	MIN. NOM. EMBEDMENT (in.)	MIN. SLAB THICKNESS (in.)	MIN. EDGE DISTANCE (in.)	ORIENTATION 1			ORIENTATION 2			ORIENTATION 3		
					30°	45°	60°	30°	45°	60°	30°	45°	60°
SAF2-3/8	3/8"	2.375	5	4	89	154	229	133	154	157	117	170	204
SAF2-1/2	1/2"	3.750	6	6	119	218	335	195	218	209	172	250	299
SAF2-5/8	5/8"	3.875	6	6	163	281	418	244	281	286	215	311	373
SAF2-3/4	3/4"	4.500	7	8	214	386	588	343	386	376	303	438	525

PART	ANCHOR DIA.	MIN. NOM. EMBEDMENT (in.)	MIN. SLAB THICKNESS (in.)	MIN. EDGE DISTANCE (in.)	ORIENTATION 1			ORIENTATION 2			ORIENTATION 3		
					30°	45°	60°	30°	45°	60°	30°	45°	60°
SAF2R-3/8	3/8"	2.375	5	4	89	154	229	133	154	157	117	170	204
SAF2R-1/2	1/2"	3.750	6	6	119	218	335	195	218	209	172	250	299
SAF2R-5/8	5/8"	3.875	6	6	163	281	418	244	281	286	215	311	373

PART	ANCHOR DIA.	MIN. NOM. EMBEDMENT (in.)	MIN. SLAB THICKNESS (in.)	MIN. EDGE DISTANCE (in.)	ORIENTATION 1			ORIENTATION 2			ORIENTATION 3		
					30°	45°	60°	30°	45°	60°	30°	45°	60°
GO-3B	3/8"	2.375	5	4	89	154	229	133	154	157	117	170	204
OR-3B													
GR-3B													
OR-4B	1/2"	3.750	6	6	119	218	335	195	218	209	172	250	299
GR-4B													

APPENDIX

Maximum Load for Wedge Anchors in 3000 psi (207 bar) Normal Weight Cracked Concrete

PART	ANCHOR DIA.	MIN. NOM. EMBEDMENT (in.)	MIN. SLAB THICKNESS (in.)	MIN. EDGE DISTANCE (in.)	ORIENTATION 1			ORIENTATION 2			ORIENTATION 3		
					30°	45°	60°	30°	45°	60°	30°	45°	60°
LPF-3/8	3/8"	2.375	5	4	189	274	342	197	274	340	170	251	297
LPF-1/2	1/2"	3.750	6	6	272	423	563	326	423	490	281	419	490
LPF-5/8	5/8"	3.875	6	6	407	623	814	472	623	733	406	605	709
LPF-3/4	3/4"	4.500	7	8	613	940	1232	715	940	1104	615	916	1073

PART	ANCHOR DIA.	MIN. NOM. EMBEDMENT (in.)	MIN. SLAB THICKNESS (in.)	MIN. EDGE DISTANCE (in.)	ORIENTATION 1			ORIENTATION 2			ORIENTATION 3		
					30°	45°	60°	30°	45°	60°	30°	45°	60°
SAF-3/8	3/8"	2.375	5	4	125	203	288	167	203	219	147	212	256
SAF-1/2	1/2"	3.750	6	6	162	295	451	263	295	285	233	337	403
SAF-5/8	5/8"	3.875	6	6	252	441	662	386	441	442	341	492	590
SAF-3/4	3/4"	4.500	7	8	378	665	999	583	665	662	515	744	892

PART	ANCHOR DIA.	MIN. NOM. EMBEDMENT (in.)	MIN. SLAB THICKNESS (in.)	MIN. EDGE DISTANCE (in.)	ORIENTATION 1			ORIENTATION 2			ORIENTATION 3		
					30°	45°	60°	30°	45°	60°	30°	45°	60°
SAFR-3/8	3/8"	2.375	5	4	125	203	288	167	203	219	147	212	256
SAFR-1/2	1/2"	3.750	6	6	162	295	451	263	295	285	233	337	403
SAFR-5/8	5/8"	3.875	6	6	252	441	662	386	441	442	341	492	590

PART	ANCHOR DIA.	MIN. NOM. EMBEDMENT (in.)	MIN. SLAB THICKNESS (in.)	MIN. EDGE DISTANCE (in.)	ORIENTATION 1			ORIENTATION 2			ORIENTATION 3		
					30°	45°	60°	30°	45°	60°	30°	45°	60°
SAF2-3/8	3/8"	2.375	5	4	125	203	288	167	203	219	147	212	256
SAF2-1/2	1/2"	3.750	6	6	162	295	451	263	295	285	233	337	403
SAF2-5/8	5/8"	3.875	6	6	252	441	662	386	441	442	341	492	590
SAF2-3/4	3/4"	4.500	7	8	378	665	999	583	665	662	515	744	892

PART	ANCHOR DIA.	MIN. NOM. EMBEDMENT (in.)	MIN. SLAB THICKNESS (in.)	MIN. EDGE DISTANCE (in.)	ORIENTATION 1			ORIENTATION 2			ORIENTATION 3		
					30°	45°	60°	30°	45°	60°	30°	45°	60°
SAF2R-3/8	3/8"	2.375	5	4	125	203	288	167	203	219	147	212	256
SAF2R-1/2	1/2"	3.750	6	6	162	295	451	263	295	285	233	337	403
SAF2R-5/8	5/8"	3.875	6	6	252	441	662	386	441	442	341	492	590

PART	ANCHOR DIA.	MIN. NOM. EMBEDMENT (in.)	MIN. SLAB THICKNESS (in.)	MIN. EDGE DISTANCE (in.)	ORIENTATION 1			ORIENTATION 2			ORIENTATION 3		
					30°	45°	60°	30°	45°	60°	30°	45°	60°
GO-3B	3/8"	2.375	5	4	125	203	288	167	203	219	147	212	256
OR-3B													
GR-3B													
OR-4B	1/2"	3.750	6	6	162	295	451	263	295	285	233	337	403
GR-4B													

Maximum Load for Wood Form Inserts in 3000 psi (207 bar) Normal Weight Cracked Concrete

PART	ANCHOR DIA.	MIN. NOM. EMBEDMENT (in.)	MIN. SLAB THICKNESS (in.)	MIN. EDGE DISTANCE (in.)	ORIENTATION 1			ORIENTATION 2			ORIENTATION 3		
					30°	45°	60°	30°	45°	60°	30°	45°	60°
LPF-3/8	3/8"	1.100	4	6	248	342	411	237	342	444	205	300	357
LPF-1/2	1/2"	1.690	4	6	297	443	565	327	443	535	282	418	492
LPF-5/8	5/8"	1.750	4	8	297	443	565	327	443	535	282	418	492
LPF-3/4	3/4"	1.750	4	8	297	443	565	327	443	535	282	418	492

PART	ANCHOR DIA.	MIN. NOM. EMBEDMENT (in.)	MIN. SLAB THICKNESS (in.)	MIN. EDGE DISTANCE (in.)	ORIENTATION 1			ORIENTATION 2			ORIENTATION 3		
					30°	45°	60°	30°	45°	60°	30°	45°	60°
SAF-3/8	3/8"	1.100	4	6	170	264	357	207	264	298	182	261	315
SAF-1/2	1/2"	1.690	4	6	192	321	468	272	321	336	240	347	416
SAF-5/8	5/8"	1.750	4	8	192	321	468	272	321	336	240	347	416
SAF-3/4	3/4"	1.750	4	8	192	321	468	272	321	336	240	347	416

PART	ANCHOR DIA.	MIN. NOM. EMBEDMENT (in.)	MIN. SLAB THICKNESS (in.)	MIN. EDGE DISTANCE (in.)	ORIENTATION 1			ORIENTATION 2			ORIENTATION 3		
					30°	45°	60°	30°	45°	60°	30°	45°	60°
SAFR-3/8	3/8"	1.100	4	6	170	264	357	207	264	298	182	261	315
SAFR-1/2	1/2"	1.690	4	6	192	321	468	272	321	336	240	347	416
SAFR-5/8	5/8"	1.750	4	8	192	321	468	272	321	336	240	347	416

PART	ANCHOR DIA.	MIN. NOM. EMBEDMENT (in.)	MIN. SLAB THICKNESS (in.)	MIN. EDGE DISTANCE (in.)	ORIENTATION 1			ORIENTATION 2			ORIENTATION 3		
					30°	45°	60°	30°	45°	60°	30°	45°	60°
SAF2-3/8	3/8"	1.100	4	6	170	264	357	207	264	298	182	261	315
SAF2-1/2	1/2"	1.690	4	6	192	321	468	272	321	336	240	347	416
SAF2-5/8	5/8"	1.750	4	8	192	321	468	272	321	336	240	347	416
SAF2-3/4	3/4"	1.750	4	8	192	321	468	272	321	336	240	347	416

PART	ANCHOR DIA.	MIN. NOM. EMBEDMENT (in.)	MIN. SLAB THICKNESS (in.)	MIN. EDGE DISTANCE (in.)	ORIENTATION 1			ORIENTATION 2			ORIENTATION 3		
					30°	45°	60°	30°	45°	60°	30°	45°	60°
SAF2R-3/8	3/8"	1.100	4	6	170	264	357	207	264	298	182	261	315
SAF2R-1/2	1/2"	1.690	4	6	192	321	468	272	321	336	240	347	416
SAF2R-5/8	5/8"	1.750	4	8	192	321	468	272	321	336	240	347	416

PART	ANCHOR DIA.	MIN. NOM. EMBEDMENT (in.)	MIN. SLAB THICKNESS (in.)	MIN. EDGE DISTANCE (in.)	ORIENTATION 1			ORIENTATION 2			ORIENTATION 3		
					30°	45°	60°	30°	45°	60°	30°	45°	60°
GO-3B	3/8"	1.100	4	6	170	264	357	207	264	298	182	261	315
OR-3B													
GR-3B													
OR-4B	1/2"	1.690	4	6	192	321	468	272	321	336	240	347	416
GR-4B													

Maximum Load for Wedge Anchors in 4000 psi (276 bar) Normal Weight Cracked Concrete

PART	ANCHOR DIA.	MIN. NOM. EMBEDMENT (in.)	MIN. SLAB THICKNESS (in.)	MIN. EDGE DISTANCE (in.)	ORIENTATION 1			ORIENTATION 2			ORIENTATION 3		
					30°	45°	60°	30°	45°	60°	30°	45°	60°
LPF-3/8	3/8"	2.375	5	4	206	293	360	208	293	370	179	264	313
LPF-1/2	1/2"	3.750	6	6	304	466	610	353	466	548	304	453	531
LPF-5/8	5/8"	3.875	6	6	469	716	935	542	716	844	467	694	814
LPF-3/4	3/4"	4.500	7	8	657	997	1293	750	997	1182	646	959	1125

PART	ANCHOR DIA.	MIN. NOM. EMBEDMENT (in.)	MIN. SLAB THICKNESS (in.)	MIN. EDGE DISTANCE (in.)	ORIENTATION 1			ORIENTATION 2			ORIENTATION 3		
					30°	45°	60°	30°	45°	60°	30°	45°	60°
SAF-3/8	3/8"	2.375	5	4	138	221	307	178	221	242	157	226	272
SAF-1/2	1/2"	3.750	6	6	188	330	495	289	330	330	255	368	442
SAF-5/8	5/8"	3.875	6	6	291	508	761	444	508	511	392	566	678
SAF-3/4	3/4"	4.500	7	8	414	711	1057	617	711	725	544	786	942

PART	ANCHOR DIA.	MIN. NOM. EMBEDMENT (in.)	MIN. SLAB THICKNESS (in.)	MIN. EDGE DISTANCE (in.)	ORIENTATION 1			ORIENTATION 2			ORIENTATION 3		
					30°	45°	60°	30°	45°	60°	30°	45°	60°
SAFR-3/8	3/8"	2.375	5	4	138	221	307	178	221	242	157	226	272
SAFR-1/2	1/2"	3.750	6	6	188	330	495	289	330	330	255	368	442
SAFR-5/8	5/8"	3.875	6	6	291	508	761	444	508	511	392	566	678

PART	ANCHOR DIA.	MIN. NOM. EMBEDMENT (in.)	MIN. SLAB THICKNESS (in.)	MIN. EDGE DISTANCE (in.)	ORIENTATION 1			ORIENTATION 2			ORIENTATION 3		
					30°	45°	60°	30°	45°	60°	30°	45°	60°
SAF2-3/8	3/8"	2.375	5	4	138	221	307	178	221	242	157	226	272
SAF2-1/2	1/2"	3.750	6	6	188	330	495	289	330	330	255	368	442
SAF2-5/8	5/8"	3.875	6	6	291	508	761	444	508	511	392	566	678
SAF2-3/4	3/4"	4.500	7	8	414	711	1057	617	711	725	544	786	942

PART	ANCHOR DIA.	MIN. NOM. EMBEDMENT (in.)	MIN. SLAB THICKNESS (in.)	MIN. EDGE DISTANCE (in.)	ORIENTATION 1			ORIENTATION 2			ORIENTATION 3		
					30°	45°	60°	30°	45°	60°	30°	45°	60°
SAF2R-3/8	3/8"	2.375	5	4	138	221	307	178	221	242	157	226	272
SAF2R-1/2	1/2"	3.750	6	6	188	330	495	289	330	330	255	368	442
SAF2R-5/8	5/8"	3.875	6	6	291	508	761	444	508	511	392	566	678

PART	ANCHOR DIA.	MIN. NOM. EMBEDMENT (in.)	MIN. SLAB THICKNESS (in.)	MIN. EDGE DISTANCE (in.)	ORIENTATION 1			ORIENTATION 2			ORIENTATION 3		
					30°	45°	60°	30°	45°	60°	30°	45°	60°
GO-3B	3/8"	2.375	5	4	138	221	307	178	221	242	157	226	272
OR-3B													
GR-3B													
OR-4B	1/2"	3.750	6	6	188	330	495	289	330	330	255	368	442
GR-4B													

Maximum Load for Wedge Anchors in 6000 psi (414 bar) Normal Weight Cracked Concrete

PART	ANCHOR DIA.	MIN. NOM. EMBEDMENT (in.)	MIN. SLAB THICKNESS (in.)	MIN. EDGE DISTANCE (in.)	ORIENTATION 1			ORIENTATION 2			ORIENTATION 3		
					30°	45°	60°	30°	45°	60°	30°	45°	60°
LPF-3/8	3/8"	2.375	5	4	225	313	379	219	313	402	189	277	329
LPF-1/2	1/2"	3.750	6	6	354	529	676	392	529	637	337	500	589
LPF-5/8	5/8"	3.875	6	6	546	812	1036	601	812	981	517	766	902
LPF-3/4	3/4"	4.500	7	8	763	1127	1429	829	1127	1370	714	1055	1243

PART	ANCHOR DIA.	MIN. NOM. EMBEDMENT (in.)	MIN. SLAB THICKNESS (in.)	MIN. EDGE DISTANCE (in.)	ORIENTATION 1			ORIENTATION 2			ORIENTATION 3		
					30°	45°	60°	30°	45°	60°	30°	45°	60°
SAF-3/8	3/8"	2.375	5	4	153	240	327	190	240	267	167	240	289
SAF-1/2	1/2"	3.750	6	6	228	382	559	326	382	400	287	414	498
SAF-5/8	5/8"	3.875	6	6	353	589	859	500	589	617	441	636	764
SAF-3/4	3/4"	4.500	7	8	496	822	1190	693	822	868	611	881	1058

PART	ANCHOR DIA.	MIN. NOM. EMBEDMENT (in.)	MIN. SLAB THICKNESS (in.)	MIN. EDGE DISTANCE (in.)	ORIENTATION 1			ORIENTATION 2			ORIENTATION 3		
					30°	45°	60°	30°	45°	60°	30°	45°	60°
SAFR-3/8	3/8"	2.375	5	4	153	240	327	190	240	267	167	240	289
SAFR-1/2	1/2"	3.750	6	6	228	382	559	326	382	400	287	414	498
SAFR-5/8	5/8"	3.875	6	6	353	589	859	500	589	617	441	636	764

PART	ANCHOR DIA.	MIN. NOM. EMBEDMENT (in.)	MIN. SLAB THICKNESS (in.)	MIN. EDGE DISTANCE (in.)	ORIENTATION 1			ORIENTATION 2			ORIENTATION 3		
					30°	45°	60°	30°	45°	60°	30°	45°	60°
SAF2-3/8	3/8"	2.375	5	4	153	240	327	190	240	267	167	240	289
SAF2-1/2	1/2"	3.750	6	6	228	382	559	326	382	400	287	414	498
SAF2-5/8	5/8"	3.875	6	6	353	589	859	500	589	617	441	636	764
SAF2-3/4	3/4"	4.500	7	8	496	822	1190	693	822	868	611	881	1058

PART	ANCHOR DIA.	MIN. NOM. EMBEDMENT (in.)	MIN. SLAB THICKNESS (in.)	MIN. EDGE DISTANCE (in.)	ORIENTATION 1			ORIENTATION 2			ORIENTATION 3		
					30°	45°	60°	30°	45°	60°	30°	45°	60°
SAF2R-3/8	3/8"	2.375	5	4	153	240	327	190	240	267	167	240	289
SAF2R-1/2	1/2"	3.750	6	6	228	382	559	326	382	400	287	414	498
SAF2R-5/8	5/8"	3.875	6	6	353	589	859	500	589	617	441	636	764

PART	ANCHOR DIA.	MIN. NOM. EMBEDMENT (in.)	MIN. SLAB THICKNESS (in.)	MIN. EDGE DISTANCE (in.)	ORIENTATION 1			ORIENTATION 2			ORIENTATION 3		
					30°	45°	60°	30°	45°	60°	30°	45°	60°
GO-3B	3/8"	2.375	5	4	153	240	327	190	240	267	167	240	289
OR-3B													
GR-3B													
OR-4B	1/2"	3.750	6	6	228	282	559	326	382	400	287	414	498
GR-4B													

Piping Weights for Determining Horizontal Load	
Nominal Dimension	Weight of Water Filled Pipe

CPVC Pipe	
in.	lbs/ft
¾	0.44
1	0.67
1 ¼	1.08
1 ½	1.41
2	2.20
2 ½	3.26
3	4.83

Diameter of Piping in Inches	Total Length of Piping in ft.								
	1	5	10	15	20	25	30	35	40
¾	0.44	2.20	4.40	6.60	8.80	11.00	13.20	15.40	17.60
1	0.67	3.35	6.70	10.05	13.40	16.75	20.10	23.45	26.80
1 ¼	1.08	5.40	10.80	16.20	21.60	27.00	32.40	37.80	43.20
1 ½	1.41	7.05	14.10	21.15	28.20	35.25	42.30	49.35	56.40
2	2.20	11.00	22.00	33.00	44.00	55.00	66.00	77.00	88.00
2 ½	3.26	16.30	32.60	48.90	65.20	81.50	97.80	114.10	130.40
3	4.83	24.15	48.30	72.45	96.60	120.75	144.90	169.05	193.20

SCHEDULE 7 PIPE WEIGHTS

Piping Weights for Determining Horizontal Load	
Nominal Dimension	Weight of Water Filled Pipe

Schedule 7 Pipe	
in.	lbs/ft
1 ¼	1.904
1 ½	2.586
2	3.631
2 ½	4.998
3	7.090
4	10.669
6	21.900

Diameter of Piping in Inches	Total Length of Piping in ft.								
	1	5	10	15	20	25	30	35	40
1 ¼	1.904	9.52	19.04	28.56	38.08	47.60	57.12	66.61	76.16
1 ½	2.586	12.93	25.86	38.79	51.72	64.65	77.58	90.51	103.44
2	3.631	18.16	36.31	54.47	72.62	90.78	108.93	127.09	145.24
2 ½	4.998	24.99	49.98	74.97	99.96	124.95	149.94	174.93	199.92
3	7.090	35.45	70.90	106.35	141.80	177.25	212.70	248.15	283.60
4	10.669	53.35	106.69	160.04	213.38	266.73	320.07	373.42	426.76
6	21.900	109.50	219.00	328.50	438.00	547.50	657.00	766.50	876.00

SCHEDULE 10 PIPE WEIGHTS

Piping Weights for Determining Horizontal Load	
Nominal Dimensions	Weight of Water-Filled Pipe

Schedule 10 Pipe	
in.	lb/ft
1	1.81
1¼	2.52
1½	3.04
2	4.22
2½	5.89
3	7.94
3½	9.78
4	11.78
5	17.3
6	23.03
8	40.08

Diameter of Piping in Inches	Total Length of Piping in ft								
	1	5	10	15	20	25	30	35	40
1	1.81	9.05	18.1	27.15	36.2	45.25	54.3	63.35	72.4
1¼	2.52	12.6	25.2	37.8	50.4	63	75.6	88.2	100.8
1½	3.04	15.2	30.4	45.6	60.8	76	91.2	106.4	121.6
2	4.22	21.1	42.2	63.3	84.4	105.5	126.6	147.7	168.8
2½	5.89	29.45	58.9	88.35	117.8	147.25	176.7	206.15	235.6
3	7.94	39.7	79.4	119.1	158.8	198.5	238.2	277.9	317.6
3½	9.78	48.9	97.8	146.7	195.6	244.5	293.4	342.3	391.2
4	11.78	58.9	117.8	176.7	235.6	294.5	353.4	412.3	471.2
5	17.3	86.5	173	259.5	346	432.5	519	605.5	692
6	23.03	115.15	230.3	345.45	460.6	575.75	690.9	806.05	921.2
8	40.08	200.4	400.8	601.2	801.6	1002	1202.4	1402.8	1603.2

SCHEDULE 40 PIPE WEIGHTS

Piping Weights for Determining Horizontal Load	
Nominal Dimensions	Weight of Water-Filled Pipe

Schedule 40 Pipe	
in.	lb/ft
1	2.05
1¼	2.93
1½	3.61
2	5.13
2½	7.89
3	10.82
3½	13.48
4	16.4
5	23.47
6	31.69
8	47.7

Diameter of Piping in Inches	Total Length of Piping in ft								
	1	5	10	15	20	25	30	35	40
1	2.05	10.25	20.5	30.75	41	51.25	61.5	71.75	82
1¼	2.93	14.65	29.3	43.95	58.6	73.25	87.9	102.55	117.2
1½	3.61	18.05	36.1	54.15	72.2	90.25	108.3	126.35	144.4
2	5.13	25.65	51.3	76.95	102.6	128.25	153.9	179.55	205.2
2½	7.89	39.45	78.9	118.35	157.8	197.25	236.7	276.15	315.6
3	10.82	54.1	108.2	162.3	216.4	270.5	324.6	378.7	432.8
3½	13.48	67.4	134.8	202.2	269.6	337	404.4	471.8	539.2
4	16.4	82	164	246	328	410	492	574	656
5	23.47	117.35	234.7	352.05	469.4	586.75	704.1	821.45	938.8
6	31.69	158.45	316.9	475.35	633.8	792.25	950.7	1109.15	1267.6
8	47.7	238.5	477	715.5	954	1192.5	1431	1669.5	1908

Concrete Anchor Orientations & Respective Prying Factor Formula

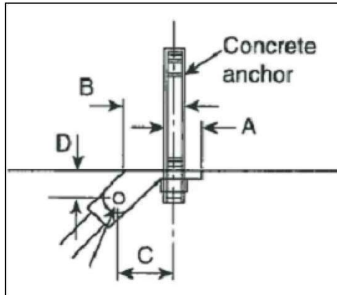

$$Pr = \frac{\left(\frac{C + A}{\tan\theta}\right) - D}{A}$$

Orientation 1, Angles "A", "B", and "C".

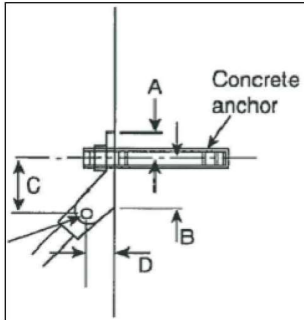

$$Pr = \frac{(C + A) - \left(\frac{D}{\tan\theta}\right)}{A}$$

Orientation 2, Angles "D", "E", and "F".

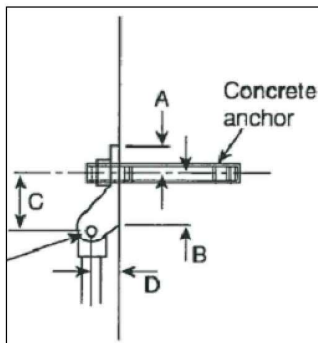

$$Pr = \frac{\left(\frac{D}{B}\right)}{\sin\theta}$$

Orientation 3, Angles "G", "H", and "I".

	30°	45°	60°
Sin	0.5	0.7071	0.866
Tan	0.5773	1	1.732

Seismic Coefficient Table				
S_s	C_p		S_s	C_p
0.33 or Less	0.35		1.7	0.79
0.4	0.38		1.75	0.82
0.45	0.39		1.8	0.84
0.5	0.4		1.85	0.865
0.55	0.41		1.9	0.89
0.6	0.42		1.95	0.91
0.65	0.42		2	0.93
0.7	0.42		2.05	0.955
0.75	0.42		2.1	0.98
0.8	0.44		2.15	1.005
0.85	0.46		2.2	1.03
0.9	0.48		2.25	1.05
0.95	0.5		2.3	1.07
1	0.51		2.35	1.095
1.05	0.525		2.4	1.12
1.1	0.54		2.45	1.145
1.15	0.555		2.5	1.17
1.2	0.57		2.55	1.19
1.25	0.58		2.6	1.21
1.3	0.61		2.65	1.235
1.35	0.63		2.7	1.26
1.4	0.65		2.75	1.285
1.45	0.675		2.8	1.31
1.5	0.7		2.85	1.33
1.55	0.725		2.9	1.35
1.6	0.75		2.95	1.375
1.65	0.77		3	1.4

Data Derived from NFPA-13 2010

The below formula was used to calculate the table above.

$$C_p = C_{p-low} + \frac{C_{p-high} - C_{p-low}}{S_{s-high} - S_{s-low}} (S_s - S_{s-low})$$



How-To Video Series



Seismic Calculator

901 INDUSTRIAL BLVD.
NAPLES, FL 34104
800.321.LOOS (5667)
LOOSSEISMICBRACING.COM